

HUNTRON

Huntron Access DH2

USER'S MANUAL

P/N 21-2637

**Rev. B
Version 1.3**

January, 2022

Copyright © 2021 Huntron, Inc. All rights reserved.

Huntron, Tracker, ProTrack, and Huntron Access are registered trademarks of Huntron, Inc. All other names are trademarks or registered trademarks of their respective companies.

This document may not be copied in whole or in part, or otherwise reproduced except as specifically permitted under U.S. copyright law, without the prior written consent of Huntron, Inc., 15720 Main Street, Suite #100, Mill Creek, WA, 98012, USA.

HUNTRON, INC.

LIMITED WARRANTY

Huntron, Inc. believes in the quality of its products. Accordingly, Huntron provides the following non-transferable warranties for the benefit of the original end-use purchaser of the Huntron Access DH2.

Huntron warrants that the Huntron Access DH2 hardware shall be free from defects in material and workmanship for one (1) year from the date of purchase.

Huntron warrants that the CD containing the Huntron Workstation for Windows software shall be free from defects in material and workmanship for one (1) year from the date of purchase. Huntron further warrants that the software will perform in substantial conformance with the system specifications of the Huntron Access DH2 at the time of purchase and for the period of one (1) year thereafter.

The above warranties are in lieu of all other warranties, express or implied, including all warranties of merchantability and/or fitness for a particular purpose. Huntron's liability under these warranties, including any damages sustained by the customer through malfunction or failure of the Huntron software, shall not exceed the amount of the purchase price of the Huntron Access DH2, regardless of the extent of any such damage, including any special, consequential, or incidental damages of any kind.

These warranties shall only apply to products in ordinary use. Huntron shall have no obligation under these warranties with respect to damage caused by accident, transportation, neglect, misuse, unauthorized alterations or repair, improper installation, or operating conditions.

Products purchased in the United States are to be returned to Huntron, Inc. at its factory, transportation prepaid. Products purchased outside the United States are to be returned to the source of purchase for Warranty repair.

Written notice of, and an explanation of the circumstances of, any defect believed to be covered by this agreement shall be provided promptly to Huntron by the customer following discovery of the defect. In satisfaction of its warranty liability, Huntron agrees to take reasonable and prompt action to correct the defect, either by repair or replacement, at its option.

Contacting Huntron

To obtain information about service, accessories and other products, contact:

Huntron Inc.
15720 Main Street, Suite #100
Mill Creek, WA 98012 USA
Phone: 800-426-9265 or 425-743-3171
FAX: 425-743-1360
E-mail: info@huntron.com
Website: huntron.com

Table of Contents

SECTION 1 INTRODUCTION	7
1-1 Introduction	7
1-2 Hardware and Software	8
Hardware Features of the Huntron Access DH2	8
Software applications for the Huntron Access DH2	8
1-3 Specifications	10
Specifications of Huntron Access DH2 Models	10
Specifications for Access DH2 Tracker	12
1-4 Safety Information (Information sur la sécurité)	13
1-5 Environment Conformity Quality	17
Environment	18
Conformity	18
Quality	18
SECTION 2 THEORY OF OPERATION	19
2-1 Introduction	19
2-2 Functional Overview	19
2-3 Stepper Motor Controller	19
2-4 Stepper Motor Drivers	19
2-5 XY Linear Encoders	19
2-6 Z linear Encoders	19
2-7 Vision System	19
2-8 Internal PDU	20
Safety	20
Operation	20
2-9 Controls and Signal Connections	20
System Power Switch	20
System Power Cord	20
Emergency Stop Button	20
Prober Stop Switch	21
Door Key Switch	21
Rear Panel Banana Jacks	21
Channel A Banana Jack	21
Common Banana Jack	21
Common 1 Banana Jack	21
Common 2 Banana Jack	21
Common 3 Banana Jack	22
Common 4 Banana Jack	22
Control Chassis Front Panel Connections	22
Electronic Chassis Power Switch	22
OUT Bananas	22
Scope BNC (early versions)	22
Tracker BNC (early versions)	22

Common BNC (early versions)	22
Signal BNC	22
DMM Bananas.....	22
PG Banana.....	22
Prober Motor Control Connections	23
Z Probe Motor DIN Connectors	23
Z Probe Encoder DIN Connectors	23
Z Probe Limit DIN Connectors.....	23
Z Probe Signal SMA Connectors.....	23
Z Probe Brake Connectors	23
SECTION 3 INSTALLATION	24
3-1 Installing Hardware.....	24
3-2 Starting System	24
SECTION 4 HARDWARE MAINTENANCE	25
4-1 Lubrication	25
Procedure.....	25
4-2 Calibration Requirements	26
4-3 Spring Contact Probes.....	27
4-4 Cover Door	28
4-5 Casters and Leveling	28
4-6 Front Bottom Doors.....	28
4-7 Removable Panels.....	28
4-8 Internal 19" Rack	28
4-9 Monitor Arm Bracket.....	28
4-10 Internal Controller	28
4-11 Keyboard.....	28
4-12 Mouse	29
4-13 Monitor.....	29
4-14 Top Cover.....	29
4-15 Virginia Panel S6 (Not Supplied).....	29
4-16 Cleaning	29
SECTION 5 PCA SUPPORT ACCESSORIES	30
Documents.....	30
SECTION 6 TESTING PASSIVE COMPONENTS.....	31
6-1. Resistors.....	31
Micro Probe Adjustment.....	31
The Effect of R_s on Resistor Analog Signatures.	33
The Effect of V_s on Resistor Analog Signatures.	33
The Effect of F_s on Resistor Analog Signatures.....	34
Shorts and Opens, Resistor Faults	34
Review.....	35
Applications.....	35
6-2 Capacitors	36
Capacitor Analog Signatures.....	36

Signatures of Capacitors	37
Effect of Frequency (F_s) on the Signature of a 10 μ F Capacitor	37
Effect of Frequency (F_s) on the Signature of a 0.1 μ F Capacitor	38
Effect of Voltage (V_s) on the Signature of a 1 μ F Capacitor	38
Effect of Resistance (R_s) on the Signature of a 1 μ F Capacitor.....	38
Understanding Capacitor Analog Signatures.....	39
Capacitor Leakage Failures	41
Review.....	42
Applications.....	42
6-3 Inductors	43
Inductor Analog Signature	43
Signatures of Inductors in 50 Ω , 10V and 2KHz.....	43
Effect of Frequency (F_s) on Inductor Signatures.....	44
Effect of Voltage (V_s) on Inductor Signatures.....	44
Effect of Internal Resistance (R_s) on Inductor Signatures	45
Understanding Inductive Signatures.....	45
Applications.....	46
6-4 Electromechanical Switching Components	48
Manually Operated Mechanical Switches	48
Review.....	48
Electromechanical Relays	49
Review.....	50
SECTION 7 TESTING DISCRETE SEMICONDUCTORS	51
7-1. Diodes	51
Diode Analog Signatures.....	51
Effects of Frequency (F_s) on Diode Signatures	53
Effects of Internal Resistance (R_s) on Diode Signatures	53
Composite Diode Signatures.....	54
Diode Failures	55
Internal Resistance Flaw in a Diode.....	55
Internal Leakage in a Diode	57
Zener Diodes	57
Review.....	59
Applications.....	59
7-2 Transistors.....	60
Bipolar Transistor Signatures.....	61
Bipolar Transistor Base-Collector Signatures	61
Identifying Unknown Transistors.....	63
Darlington Bipolar Transistor Signatures.....	64
Applications.....	65
7-3 Solid State Switching Components.....	66
Optical Switches.....	66
Phototransistor	66

SCRs and TRIACs.....	67
Silicon Controlled Rectifiers (SCRs).....	67
Review.....	68
Applications.....	68
SECTION 8 TESTING INTEGRATED CIRCUITS	69
8-1 Digital Integrated Circuits	69
Integrated Circuit Failures.....	69
Digital Integrated Circuit Signatures.....	70
Signatures of a Digital IC	70
Signatures of Logic IC Families	71
Comparing Two TTL Families	72
CMOS Logic Family.....	73
CMOS Components and Test Frequency (F_s).....	74
Troubleshooting Digital Logic ICs.....	74
Review.....	75
Applications.....	75
8-2 Analog Circuits	76
Op Amps.....	76
Op Amp Signatures	76
Troubleshooting Op Am Circuits.....	77
Linear Voltage Regulators.....	78
Review.....	79
Applications.....	79
8-3 Low Voltage Integrated Circuits.....	80
Review.....	81
Applications.....	81
SECTION 9 APPLICATION NOTES	82
9-1 How to Use Commons	82
9-2 Access DH2 Connection Diagram.....	83

SECTION 1 INTRODUCTION

1-1 Introduction

The Huntron Access DH2 prober is a universal test fixture for accessing test points on printed circuit assemblies (PCAs). The Huntron Access DH2 provides physical access to fine pitched PCAs and be combined with other test instruments such as DMMs, Oscilloscope, Signal Generator, LCR meter, Functional Tester, In-circuit Tester or Analog Signature Analyzer. The Huntron Access DH2 allows test engineers and technicians to test and troubleshoot their difficult and elusive problems on PCAs. The Huntron Access DH2 has a Tracker Model 3200S Main PCA built inside that is referred to as the Access DH2 Tracker.

The user can replace the built-in test probe with a custom probe suitable for the user's custom application. The Z-axis Probe and Camera, can be replaced by a user specified Z-axis.

The Huntron Access DH2 basically consists of three axes which move two test probes along an XY plane. Once the probe reaches an XY coordinate, an up or down Z movement can be initiated so that the test probe contacts a test point on the target PCA. Each X, Y and Z stage is driven by a separate stepper motor.

The color camera installed on the Z axis displays a high-resolution image of the PCA on the PC monitor. Using linear encoders and micro-stepping, accurate and repeatable movements can be achieved.

This Manual covers the following products:
Access DH2

1-2 Hardware and Software

A complete troubleshooting workstation consists Huntron Access DH2 and optionally a Test Instrument.

Hardware Features of the Huntron Access DH2

- The XYZ stages are stainless steel linear rails providing an accurate means of moving a load.
- Uses linear encoders for the X, Y and Z axes which provide feedback for error correction.
- The X and Y linear stages use belts which are driven by stepper motors.
- Micro-stepping drivers can micro-step the XYZ stepper motors.
- Connection to any external tracker or other tester is via connectors on the front of the electronics chassis inside the lower front doors of the Access DH2.
- A camera mounted on each Z axis produces a digitized color image of an area of the PCA on the PC monitor. These are high-resolution color cameras with auto focus. Ring lights are attached to each camera. Digitizing test points then involves clicking on the pixels of the camera image.
- Encoder reference marks and limit switches are used to define the XY “home” positions.
- Light proximity limit switches are used to define the Z “home” positions.
- The test probe tip mounted on the Z axis is a removable standard “bed-of-nails” type spring loaded probe tip. Different probe tips are supplied covering conformal coating applications to fine pitched crown pointed tips.
- A Prober Stop switch allows immediate suspension of Huntron Access DH operation.
- The Emergency Stop Red mushroom button turns off the power to the system.
- There are Channel A and 5 Common banana jacks accessible in the probing area which allows connection to the printed circuit assembly signal reference points.
- An internal 19” Rack is mounted in the cabinet for mounting equipment.
- Cover door Stops the Access DH2 when the cover key switch is in the normal position. In the Interlock Bypass position the door can be opened without stopping the Access DH2. (See the safety section of the manual for proper use).
- Integrated PC with monitor, keyboard and mouse mounted on an included monitor arm.
- Integrated PDU with Power and Emergency Shutdown controls

Software applications for the Huntron Access DH2

- Can be used with the Huntron Workstation software for power-off troubleshooting of PCAs.
- Optional Huntron Workstation Remote Control allows Huntron Workstation to be controlled by custom programs.

- Optional Huntron Hardware SDK allows creation of custom programs to control the Huntron Access and Huntron Trackers.
- Optional Huntron Workstation SDK allows other instruments to be controlled by the Huntron Workstation software.

1-3 Specifications

Specifications of Huntron Access DH2 Models

Specification	Huntron Access DH2	Comments
Physical Dimensions	47" W, 35.75" D, 61.5" H 119.4cm W, 83.8cm D, 156.2cm H	
Max board probing area	19" W by 12" D 48.3 cm W by 30.5 cm D	Area of the board that both probes can reach.
Max Z Travel	6" 15.24 cm	Maximum allowable up/down movement
XY Minimum resolution	0.0000157" 0.4 microns	Minimum allowable movement in the X or Y direction
XY Movement Accuracy	0.000787" 20 microns	Over a travel distance of 10" (25.4 cm)
Vision system	2 High Resolution Cameras	
Lens system	Wide angle, Auto focus	
XY Linear Encoder Resolution	0.0000394" 1 micron	
Z Rotary Encoder Resolution	0.0000394" 1 micron	
Weight	633 lbs. 287 kg	Unit only
System (PDU) Power requirements	100V~ 16A 60Hz 115V~ 16A 60Hz 230V~ 16A 50Hz	
PDU Output	10A Max each Receptacle, 16A Total.	Take in to consideration that the equipment supplied in the system use the follow of the available current. 100Vac, 3.0A, 60Hz; 115Vac, 2.6A, 60Hz; 230Vac, 1.3A, 50Hz
Electronic Chassis Fuse	T2A 5x20mm 250V	
Computer interface	USB 3.1	
Operating temperature	59 degrees F to 86 degrees F (+15 degrees C to +30 degrees C)	
Storage temperature	32 degrees F to 104 degrees F (0 degrees C to +40 degrees C)	
Operating Humidity	45 to 70% R.H.	
Storage Humidity	0 to 70% R.H.	
Use	In Door Use Only	
Altitude	Up to 2000M	
Mains Supply Voltage Fluctuations	Up To +/-10% of the Nominal Voltage	
Transient Over Voltages	Up to levels of Over Voltage Category II;	

	NOTE 1 These levels of transient overvoltage are typical for equipment supplied from the building wiring.	
Applicable Pollution	Pollution Degree 2	
Safety considerations	Front panel Probe Stop switch and Emergency Stop switch	CE mark and ETL listed

Specifications for Access DH2 Tracker

Electrical	Specifications subject to change without notice
Open Circuit Voltage (Vs):	
24 selections of peak voltage:	200mV, 400mV, 600mV, 800mV, 1V to 20V in 1V steps including 10V (Low), 15V (Med 1), 20V (Med 2)
Source Resistance (Rs):	
16 selections of resistance:	10 Ω , 20 Ω , 50 Ω , 100 Ω , 200 Ω , 500 Ω , 1k Ω , 2k Ω , 5k Ω , 10k Ω , 20k Ω , 50k Ω , 100k Ω , 54k Ω (Low), 1.2k Ω (Med 1), 26.7k Ω (Med 2)
Short circuit current (Vs divided by Rs)	
Maximum	200 mApk
Frequency (fs):	
40 selections of frequency:	20Hz to 190Hz in 10Hz steps; 200Hz to 1.9kHz in 100Hz steps; 2kHz to 5kHz in 1kHz steps
Channels	
Number	1
Over Voltage Protection	Circuit breaker

1-4 Safety Information (Information sur la sécurité)

The Huntron Access DH2 should only be used in the manner specified in this manual. The protection provided by the Huntron Access DH may be impaired if used in any other manner.

Le Huntron Access DH2 ne doivent être utilisés de la manière indiquée dans ce manuel. La protection prévue par le Huntron Access DH peut être altérée en cas d'utilisation de toute autre manière.

Symbols and Warnings: (Symboles et avertissements)

The following symbols are used either in this manual or on the unit:

Les symboles suivants sont utilisés soit dans ce manuel ou sur l'appareil:



Protective Ground (Earth) Terminal: Do not disconnect any protective ground wires.

Rez de protection (terre): Ne débranchez pas les fils de terre de protection.



CAUTION: This symbol is used in the user's manual as a warning that improper use could result in unit malfunctioning. For your safety always follow the instructions next to the symbol on the unit and in the manual.

ATTENTION: Ce symbole est utilisé dans le manuel de l'utilisateur comme un avertissement que l'usage abusif peut entraîner des dysfonctionnements unité. Pour votre sécurité toujours suivre les instructions à côté du symbole de l'unité et dans le manuel.



This symbol warns the user that spring-loaded probe which is mounted on the Z axis is sharp and can scratch or punch the skin.

Ce symbole prévient l'utilisateur que la sonde à ressort qui est monté sur l'axe Z est net et peuvent rayer ou le poinçon de la peau.



This symbol warns the user that this is a pinch point / Crush hazard were the Z axis and X axis move to their limits forward/back and left/right. The user should not have their fingers or hands near this point while the unit is in motion.

Ce symbole prévient l'utilisateur qu'il s'agit d'un point de pincement / écrasement de risque étaient l'axe Z et l'axe X sont à placer aux limites avant / arrière et droite / gauche. L'utilisateur ne devrait pas avoir les doigts ou les mains près de ce point lorsque l'appareil est en mouvement.



**Disconnection means is to disconnect the AC Inlet from power.
les moyens de déconnexion est de débrancher la prise secteur de l'alimentation.**

The Access DH2 panels should only be opened / removed by properly trained personnel. There are hazardous voltages behind the panel. Always disconnect the AC Inlet from power before opening/removing the panels.

Les panneaux Access DH2 ne doivent être ouverts / retirés que par un personnel correctement formé. Il y a des tensions dangereuses derrière le panneau. Débranchez toujours l'entrée CA de l'alimentation avant d'ouvrir / retirer les panneaux.



Cover door stops the Access DH2 when the DOOR key switch is in the Normal position. Disable the Access DH2 before opening the door to insert/remove a PCA under test. Enable the Access DH2 to resume use. When the door is open, observe over warning labels and their associated warnings.

In the Interlock Bypass position the door can be opened without stopping the Access DH2. Only personnel that have properly trained in the use of equipment with moving parts

should open the Access DH2 cover door with the key in the Interlock Bypass position. For safety always close the door when mechanism is moving.

La porte du couvercle arrête l'accès DH2 lorsque l'interrupteur à clé DOOR est en position normale. Désactivez l'accès DH2 avant d'ouvrir la porte pour insérer / retirer un PCA en cours de test. Activez l'accès DH2 pour reprendre l'utilisation. Lorsque la porte est ouverte, observez les étiquettes d'avertissement et les avertissements associés.

En position Interlock Bypass, la porte peut être ouverte sans arrêter l'accès DH2. Seul le personnel ayant reçu une formation adéquate sur l'utilisation de l'équipement avec des pièces mobiles doit ouvrir la porte du couvercle Access DH2 avec la clé en position de verrouillage. Pour votre sécurité, fermez toujours la porte lorsque le mécanisme est en mouvement.



This label warns of the following:

IEC Laser Safety Class Definitions pertinent to NERLITE LED Product: IED Class Code 1 Definition.

Considered as safe eye and skin damage under all reasonably foreseeable conditions of operation.

Cette étiquette avertit de ce qui suit:

Définitions de la classe de sécurité laser CEI relatives au produit DEL NERLITE: code de classe IED 1 Définition.

Considéré comme endommageant les yeux et la peau en toute sécurité dans toutes les conditions d'exploitation raisonnablement prévisibles.

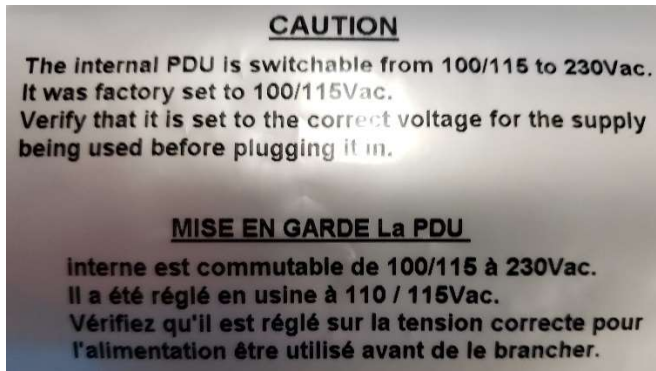

CAUTION

The internal PDU is switchable from 100/115 to 230Vac.
It was factory set to 110/115Vac.
Verify that it is set to the correct voltage for the supply
being used before plugging it in.

MISE EN GARDE La PDU

interne est commutable de 100/115 à 230Vac.
Il a été réglé en usine à 110 / 115Vac.
Vérifiez qu'il est réglé sur la tension correcte pour
l'alimentation être utilisé avant de le brancher.



All Huntron Access DH2 models conform to the following Standards:

IEC 61010-1:2010, AMD1:2016

Safety requirements for Electrical Equipment for Measurement, Control, and Laboratory Use; Part 1: General Requirements (ANSI/UL 61010-1:2012 Ed.3+R:29 Apr2016)

Safety requirements for Electrical Equipment for Measurement, Control, and Laboratory Use; Part 1: General Requirements (CAN/CSA C22.2 No.61010-1-12:2012 Ed.3+U1; U2. R2017)

EN 61326-1: 2013

IEC 61326-1: 2012

FCC Part 15, Sub Part B

Industry Canada ICES-003



The Standard for Safety Requirements for Electrical Equipment for Measurement, Control and Laboratory Use; Part 1 General Requirements – UL 61010-1:2012 Ed.3+R29 Apr 2016, and CSA C22.2#61010-1-12:2012 Ed.2+U1;U2.

Line Fuse Replacement: (Line Remplacement des fusibles)

Line Fuse tray: The power entry module includes a power switch, power cord connector, and a removable tray which selects the line voltage and holds the line fuses.

Line bac Fuse: Le module d'entrée d'alimentation comprend un interrupteur, connecteur cordon d'alimentation, et un plateau amovible qui permet de sélectionner la tension de ligne et détient les fusibles en ligne.

Make sure to remove AC power from the system. Make sure that replacement fuses are of the type and current rating specified. If necessary, insert a T2A 5x20mm 250V fuse into the fuse tray.

Assurez-vous de retirer l'alimentation CA du système. Assurez-vous que les fusibles de rechange sont du type et du courant spécifiés. Si nécessaire, insérez un fusible T2A 5x20mm 250V dans le porte-fusible.

Power Cord Replacement: (Remplacement du cordon d'alimentation)

Power Cord: Only replace the main power cord with a cord with NEMA 5-15 Power Plug and IEC 60320 C19 connector. The cord must be rate at 20A and voltage of the power source used. UL listed 12AWG wire.

Cordon d'alimentation: Remplacez le cordon d'alimentation uniquement par un cordon avec prise d'alimentation NEMA 5-15 et connecteur IEC 60320 C19. Le cordon doit être réglé à 20A et la tension de la source d'alimentation utilisée. Fil 12AWG.

Replacing the main power cord that does not meet the requirements can cause damage to the equipment and harm personnel.

Le remplacement du cordon d'alimentation principal qui ne répond pas aux exigences peut endommager l'équipement et blesser le personnel.

1-5 Environment Conformity Quality

For more information see our website www.huntron.com/corporate/environment.htm

Environment



Huntron is aware of the recycling needs for Waste Electronic and Electrical Equipment (WEEE) and is co-operating with systems established, worldwide for the collecting and recycling of our products.

Huntron has applied the wheeled bin recycle mark (EN50419) to our products.



Recycling is important to all communities; therefore, we ask our customers to be responsible in recycling. Please check your local recycling laws for further information.

Huntron wants to make sure that old Huntron products are responsibly recycled. As part of that goal, Huntron offers a trade-in for any one used Tracker or Prober when a new Tracker or Prober is purchased. All trade-in products are responsibly recycled. More information on Trade-in program go to www.huntron.com/sales-support/repairpolicy.htm.

Conformity

Huntron products are classified as Category 9 industrial monitoring and control instruments. Our manufacturing processes conform to our standards. These include regulation and directives like RoHS2, REACH and Conflict Minerals. See our Declaration of Conformity to Huntron Quality Standard at www.huntron.com/corporate/docs/conformity.pdf.

Quality

Huntron has been producing quality products and supporting customers all over the world for several decades. Our products conform to our Quality Manual. For information see our Quality Statement at www.huntron.com/corporate/docs/quality-statement.pdf.

SECTION 2 THEORY OF OPERATION

2-1 Introduction

The purpose of this section is to simply explain the functional characteristics of the main components of the Huntron Access system.

2-2 Functional Overview

The connection of instruments to the Test probe on each Z axis is directly is controlled by the software. The vision system displays an image of a small area of the PCA on the PC monitor for setting up the XY locations of test points.

2-3 Stepper Motor Controller

The Stepper Motor Controller receives ASCII commands through USB from the PC. The controller applies direction pulses for clockwise or counter-clockwise rotation and step pulses at different frequencies to the motor driver.

2-4 Stepper Motor Drivers

The purpose of the Motor Drivers is to supply sufficient and regulated current to each phase of the motor winding. The Motor driver uses micro-stepping, dividing each motor step into fractional steps, thus allowing very small movements useful for accuracy and error correction.

2-5 XY Linear Encoders

Linear encoders are used to report to the system the exact location of the Z axis housing which holds the test probe. Optical readers mounted in each axis read the engraved lines on a metal tape. The optical reader automatically outputs signals to the controller, thus reporting its position after every movement. The reported position is then compared to the theoretical position and corrections are made by the control software. The linear encoder serves as the most important function for maintaining accuracy of movements.

2-6 Z linear Encoders

Linear encoders are used to report to the system the exact location of the Z probe height. The optical reader automatically outputs signals to the controller, thus reporting its position after every movement. The reported position is then compared to the theoretical position and corrections are made by the control software. The linear encoder serves as the most important function for maintaining accuracy of movements.

2-7 Vision System

The vision system consists of a high-resolution color digital camera mounted each Z axis. The color camera has high resolution. It has automatic background compensation, which

allows for digital brightness control on low or high lighting conditions. The camera uses a 16mm auto focus lens.

2-8 Internal PDU

Safety

- This product is intended for indoor use only and should not be exposed to excess moisture.
- This product is intended for installation in a restricted access location.
- Disconnect all power to the product prior to servicing.
- Do not open this product as it contains no user serviceable parts inside. All service concerns should be directed to Marway Power Solutions.
- This product is equipped with a safety ground connection through the main power inlet, as well as a redundant chassis ground strap. Ensure that the product is properly grounded before applying power.
- This product is equipped with a flanged connector as the main power inlet. Use only the correct mating connector and appropriate cordage when connecting the product to facility power.
- This product is equipped with multiple outlet receptacles. Only connect loads with the correct mating connectors.
- Observe all markings for maximum output load ratings of each receptacle and the overall product.

Operation

- The outlet receptacles labeled UNSWITCHED will be energized when main power is applied and all circuit breakers are in the ON position. The remaining outlet receptacles will be energized only when the switching circuit is enabled.
- To control the switching circuit locally, adjust the toggle switch on the front of the product to the LOCAL position. This will manually enable the switching circuit and energize all outlet receptacles.
- To control the switching circuit remotely, adjust the toggle switch to the REMOTE position. Apply a dry contact between pins 1 and 3 of a remote connector to enable the switching circuit.

2-9 Controls and Signal Connections

System Power Switch

This switch is located on the top right-hand side of the front of the Access DH2.

System Power Cord

This cord is connected to the internal PDU and can be brought out through any of the access holes.

Emergency Stop Button

The Emergency Stop button turns off the power to the system.

Note: If the Stop switch fails, disconnect the AC Inlet from Power.

Prober Stop Switch

The safety stop switch is located on the front of the Huntron Access DH2. Depressing this stop switch will cause all motor movement in the X and Y directions to immediately stop and have their respective power turned off. The software will detect that the Prober Stop switch was depressed and will not allow the user to continue operating the unit. The stop switch light illuminated in green indicates that the power is turned on. It can be used used for the following purposes:

- Stop X, Y and Z Motor operations and turn the motor power off.
- Interrupt all further instruction from the computer and stop all operations.

Door Key Switch

The door key switch allows running the Access DH2 with the cover door open:

- Bypass Interlock position allows the Assess DH2 to run with the cover door open. This should only be used by authorized personnel.
- The Normal position prevents use when the door is opened. Disable the Huntron Access DH2 in Huntron Workstation before opening the door to insert/remove a PCA under test.

Rear Panel Banana Jacks

Channel A Banana Jack

This banana jack is connected to Channel A of the internal Access DH2 Tracker or external Tracker/Tester controlled by the software. It can be used to connect a hand probe for manual probing.

Common Banana Jack

This banana jack is connected to the Common BNC and the internal Access DH2 Tracker or external Tracker/Tester controlled by the software.

Common 1 Banana Jack

This banana jack is connected to an internal software-controlled relay that connects to internal Access DH2 Tracker or external Tracker/Tester controlled by the software.

Common 2 Banana Jack

This banana jack is connected to an internal software-controlled relay that connects to internal Access DH2 Tracker or external Tracker/Tester controlled by the software.

Common 3 Banana Jack

This banana jack is connected to an internal software-controlled relay that connects to internal Access DH2 Tracker or external Tracker/Tester controlled by the software.

Common 4 Banana Jack

This banana jack is connected to an internal software-controlled relay that connects to internal Access DH2 Tracker or external Tracker/Tester controlled by the software.

Control Chassis Front Panel Connections

Electronic Chassis Power Switch

This switch is located inside the lower front doors on the front of the electronic chassis.

OUT Bananas

These Banana Jacks are connected to internal software-controlled relays that can connect it to either probe tip.

Scope BNC (early versions)

This BNC is connected to internal software-controlled relays that can connect it to either probe tip.

Tracker BNC (early versions)

This BNC is connected to internal software-controlled relays that can connect it to either probe tip. It is used to connect an external Tracker signal to the probe tips.

Common BNC (early versions)

This BNC is connected to internal software-controlled relays that can connect it to either probe tip. It is used to connect an external Tracker Common to the probe tips.

Signal BNC

This BNC is connected to internal software-controlled relays that can connect it to either probe tip. It is used to connect external Tracker Channel A to the probe tips.

DMM Bananas

These Banana Jacks are connected to internal software-controlled relays that can connect it to either probe tip.

PG Banana

This Banana Jack is connected to internal software-controlled relays that can connect it to either probe tip. It is used to connect external Tracker Pulse Generator to the probe tips.

Prober Motor Control Connections

Z Probe Motor DIN Connectors

These connectors provide the drive signals to control the motor that drives the Z Probe.

Z Probe Encoder DIN Connectors

These connectors provide the sense signals to monitor the encoder on the Z Probe motor.

Z Probe Limit DIN Connectors

These connectors provide the drive and sense signals to monitor the limit switch on the Z Probe.

Z Probe Signal SMA Connectors

These SMA connectors are for connecting signal to the probe tip.

Z Probe Brake Connectors

These connectors provide power to the Z Motor Brake.

SECTION 3 INSTALLATION

3-1 Installing Hardware

1. Locate unpackaging sheet and follow the steps
2. Make sure crossbar between the arms is removed

3-2 Starting System

1. Verify the front panel power switch is off.
2. Verify the front panel Emergency Shutdown switch is not engaged.
3. Verify that the PDU breaker is off and the toggle switch is in the Remote position (located inside the front doors).
4. Verify that the Electronic Chassis power switch is off (located inside the front doors).
5. Verify that the Voltage Selector switch on the back of the PDU inside the unit is set for the appropriate voltage (Remove and replace rear and side panels as needed).
6. Bring the power cord from inside the unit out one of the access holes (Remove and replace rear and side panels as needed).
7. Plug the power cord into an appropriate power source.
8. Turn on the PDU Breaker.
9. Turn on the front panel power switch.
10. Turn on the monitor.
11. Turn on the PC (located inside the front doors).
12. Turn on the Electronic Chassis (located inside the front doors).

SECTION 4 HARDWARE MAINTENANCE

4-1 Lubrication

The X and Y rails should be lubricated once a month. The Z rails and shaft should be lubricated once a year.

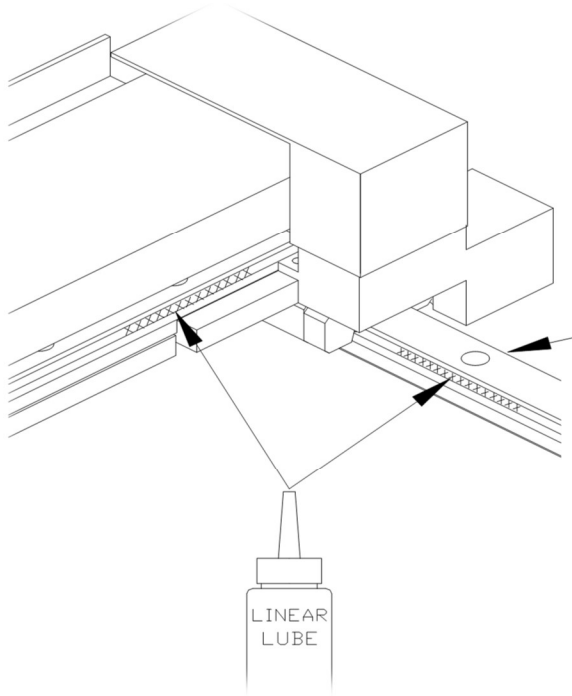

Warning: The linear raceways have to be lubricated using the supplied linear lube (Huntron Part Number 98-0116) which is included in your Tool kit. Do not use with any other lubricant.

Procedure

1. Turn the Huntron Access DH2 power off.
2. Lubing Y Rail Slide Bearings

Warning: Keep Linear Lube away from the gold encoder tape located on the underside of the Rail. If Linear Lube or dirt get onto encoder tape it can be cleaned with a lint free cloth and alcohol.

 - a. Wipe clean the rail surfaces with a lint-free cloth.
 - b. Move the Z1 Head to the center and back of prober
 - c. Apply a ½" bead of Linear Lube in each groove the Y rail. Move front to back 2 times.
 - d. Repeat step "b" 3 times.
 - e. Wipe down Y rails, especially the ends as the oil cleans out the rail slides.
 - f. Move Z1 to Home Position.
 - g. Repeat for Z2

3. Lubing Z1 X Rail Slide Bearings

Warning: Keep Linear Lube away from the gold encoder tape located on the inside of the back wall. If Linear Lube or dirt get onto encoder tape it can be cleaned with a lint free cloth and alcohol.

- a. Wipe clean the rail surfaces with a lint-free cloth.
- b. Move the Z1 Head to the back and center.
- c. Apply a ½” bead of Linear Lube in the grooves of each side of the X rails on the right side of Z1. Move to far right.
- d. Apply a ½” bead of Linear Lube in the grooves of each side of the X rails on the left side of Z1. Move Z1 left to right 3 times.
- e. Repeat step “b and c” 3 times.
- f. Wipe down X rail and any excess oil, especially the ends as the oil cleans out the rail slides.

4. Lubing Z2 X Rail Slide Bearings

Warning: Keep Linear Lube away from the gold encoder tape located on the inside of the back wall. If Linear Lube or dirt get onto encoder tape it can be cleaned with a lint free cloth and alcohol.

- a. Wipe clean the rail surfaces with a lint-free cloth.
- b. Move the Z2 Head to the back and center.
- c. Apply a ½” bead of Linear Lube in the grooves of each side of the X rails on the left side of Z2. Move to far left.
- d. Apply a ½” bead of Linear Lube in the grooves of each side of the X rails on the left side of Z2. Move Z2 right to left 3 times.
- e. Repeat step “b and c” 3 times.
- f. Wipe down X rail and any excess oil, especially the ends as the oil cleans out the rail slides.

5. Lubing Z1 Rail Slide Bearings & Motor Shaft

Consult factory before attempting to perform this task.

6. Lubing Z2 Rail Slide Bearings & Motor Shaft

Consult factory before attempting to perform this task.

4-2 Calibration Requirements

There are no user calibration requirements. The unit is factory aligned and does not need calibration.

Removing or loosening screws on the mechanical parts of the Access DH2 can affect movement accuracy.

If the unit is not moving accurately, please call Huntron Technical Support for further instructions.

4-3 Spring Contact Probes

The Huntron Access DH2 uses a spring-loaded probe for contacting a test point. Various probe styles are available depending on the type of components tested. These probes are commonly used in bed-of-nails fixtures and are readily available from a large number of manufacturers. Since the probe fits into a specific receptacle, only specific probe sizes can be used. The receptacle is a widely used industry standard size, so finding probes that fit into this receptacle should not be a problem. Manufacturers of these probes and the receptacle specifications are listed at the end of this section. Huntron can provide replacement probes and receptacles.

Generally, quality probes like those supplied are rated at 1,000,000 cycles minimum. The life expectancy depends on proper use and maintenance of the probe. We recommend that you change the test probe at least once a month for a system that is used on a regular basis.

For detailed information on replacing probe tips and the probe plate see the Huntron Access DH2 Probe Kit Instructions (21-2625).

4-4 Cover Door

- Open and close door slowly
- Replace weakened struts for safety

4-5 Casters and Leveling

- Raise feet before moving
- Lower feet in casters when unit in position

4-6 Front Bottom Doors

- Use Key latch to keep doors closed and secure
- Use latches at the top inside of the doors to remove

4-7 Removable Panels

- Side and back panels are removable by removing all screws
- Have second person hold the panel in place when removing screws so it does not drop

4-8 Internal 19" Rack

- Rear and side panels and front doors can be removed for easier access
- Rack Height: 27"
- Rack Depth to back panel: 25"
- Mount equipment as recommended by manufacturer

4-9 Monitor Arm Bracket

- Remove strap on each side of unit by removing bolts
- Attach bracket provided to preferred side using the two bolts supplied with the system
- See included instructions for assembly of the arm

4-10 Internal Controller

- The power switch is located on the front of the PC inside the front doors
- Removing the front 2 mounting screws allows the PC to slide out on rails for service
- There are front and back USB ports
- The Monitor connection is on the back (The connector is the one on the add-in card)

4-11 Keyboard

- The keyboard is normally placed on the tray of the monitor arm
- Use the provided USB extension cable to connect to the back of the controller

4-12 Mouse

- The mouse is normally placed on the tray of the monitor arm
- Use the provided USB extension cable to connect to the back of the controller

4-13 Monitor

- See the monitor arm instructions for attaching the monitor to the arm
- Use the cable included with the monitor or the longer cable provided to connect it to the back of the PC on the add-in card
- Use the power cord provided to connect to the back of the PDU

4-14 Top Cover

- Remove top rear and side panels
- Remove top row of screws from the front panel.
- Disconnect switch cables to base
- Remove six bolts attaching to base
- Close cover door
- Lift cover over all mechanisms and remove (Minimum of two people).
- For safety replace cover before operating equipment (Minimum of two people).

4-15 Virginia Panel S6 (Not Supplied)

- Remove Banana Jack panel
- Disconnect cable to Banana Jack panel
- Position cable clear of X motor path
- Attach S6 per manufacturer instructions

4-16 Cleaning

To clean the Access DH2, wipe with a damp cloth (do not use abrasives or solvents). Use plastic type polish to remove window scratches.

SECTION 5 PCA SUPPORT ACCESSORIES

Documents

See document 21-2600 Access DH2 Rotating PCB Support Instructions. It is also found on the 06-5217 Manual CD.

SECTION 6 TESTING PASSIVE COMPONENTS

6-1. Resistors

Exploring how the Access DH2 Tracker ranges interact with different resistance values is a good introduction on how basic ASA troubleshooting is applied. This section will briefly familiarize you with Access DH2 Tracker basic operation and teach you how resistor signatures relate to both test range and the resistance of the circuit under test. After completing this section, you will know how to:

- Apply test probes across a resistor
- Identify a pure resistive signature
- Analyze and predict resistive signatures

As you go through the following section, make a mental note on the relationship between the Access DH2 Tracker's test range parameters: voltage, resistance and frequency. Put the red test lead in the Channel A jack and the black test lead in the COM jack.

Micro Probe Adjustment

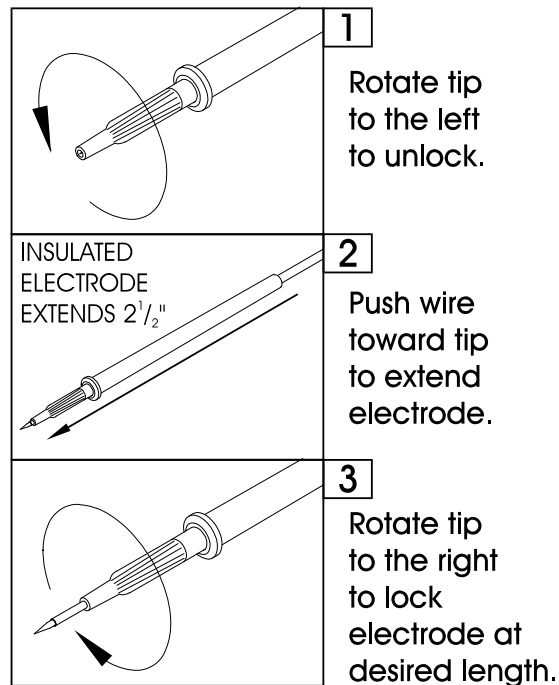
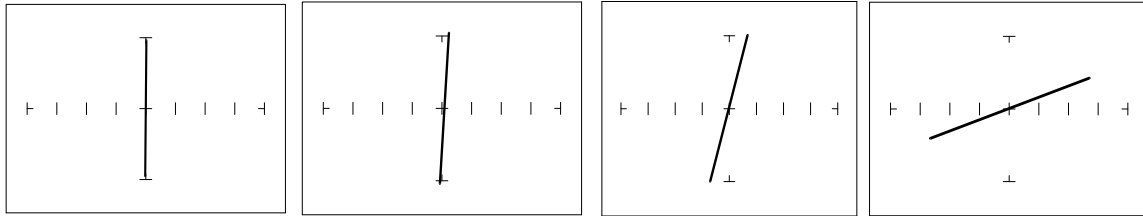

Figure 6-1. Huntron Micro Probe Adjustment.

To display the analog signature of a resistor:

1. Select the Tracker tab of the Signature pane of the Huntron Workstation Software.
2. Select the 50ohm range by clicking the Resistance dropdown button and selecting 50.
3. Place or clip a test lead on the opposite ends of a resistor and observe the signature.

Below are four analog signatures of different resistors, 150, 1.5 k, 15 k and 150 k ohms in each of the four Ranges. Note how the slope or angle of each analog signature changes with each resistor's value.



150 Ω

1.5 k Ω

15 k Ω

150 k Ω

Vs=20V, Rs=100k Ω (Use 20V, 100K, 200Hz)

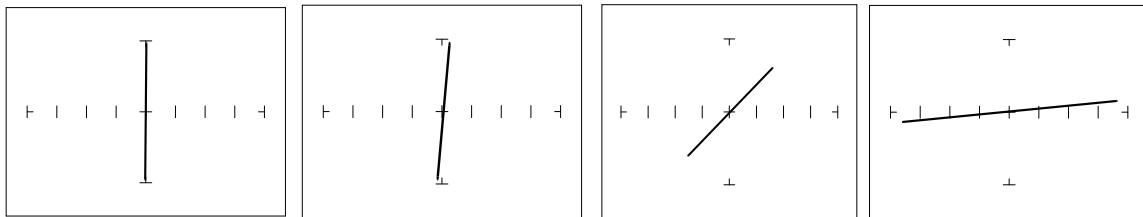

150 Ω

1.5 k Ω

15 k Ω

150 k Ω

Vs=20V, Rs=27.6k Ω (Use 20V, 20K, 200Hz)

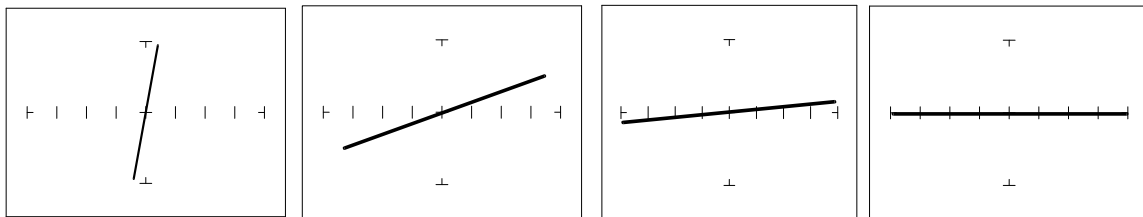

150 Ω

1.5 k Ω

15 k Ω

150 k Ω

Vs=15V, Rs=1.24k Ω (Use 15V, 1K, 200Hz)

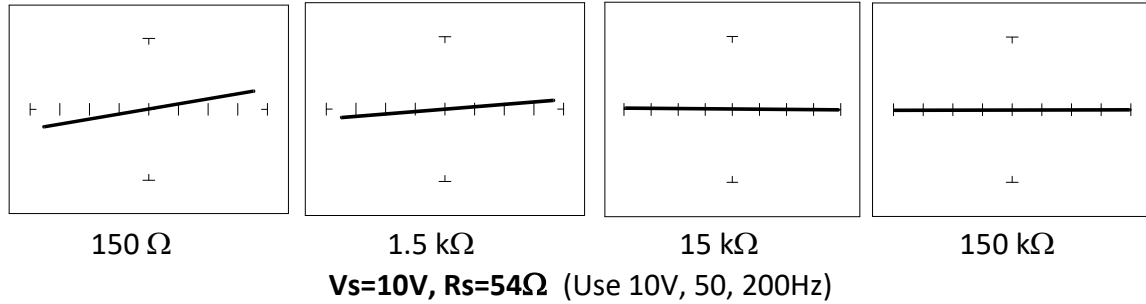

Figure 6-2. Signatures of Different Resistors in 4 Ranges.

Now that you have an idea of what the signatures of different resistor values look like in different ranges, the next part will give you an idea of what happens when you vary R_S source resistance, V_S source voltage and F_S source frequency of the Access DH2 Tracker and how it affects the resistive analog signature.

The Effect of R_S on Resistor Analog Signatures.

Select the 10V, 50 Ω and 200Hz. Change the resistance range to 200, 1K and 5K. Observe the signatures for a 150ohm resistor in the figure below as R_S varies. Note how these resistor signatures respond to changing Access DH2 Tracker's internal resistance.

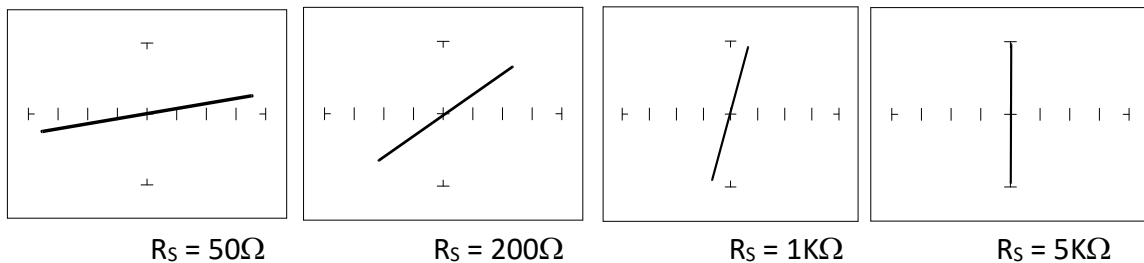

Figure 6-3. Effect of Varying R_S on a 150 Ω Resistor Signature

The Effect of V_S on Resistor Analog Signatures.

Select the 10V, 50 Ω and 200Hz. Change the voltage range to 5V, 2V and 500mV.

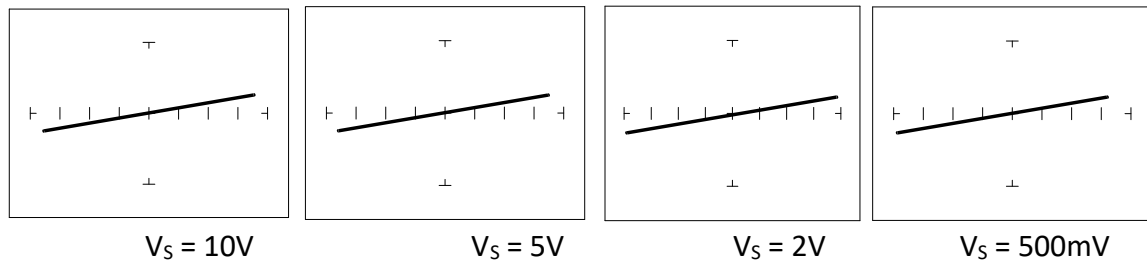
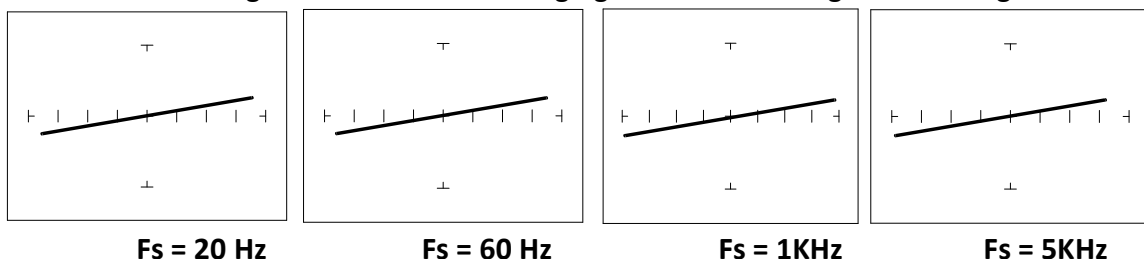

Figure 6-4. Effect of Varying V_S on a 150 Ω Resistor Signature.

Observe that these signatures do not change with the changing voltage. Note that V_S cannot be set above 10V because R_S is set to a value of 50 Ω . This limit on range parameter combinations is a result of the Access DH2 Tracker's STAR feature; it protects components from possible excessive power. In order to set V_S to a higher voltage, you must change R_S to a higher value first.

The Effect of F_s on Resistor Analog Signatures.

Select the 10V, 50 Ω and 20Hz range. Change the Frequency to 60Hz, 1KHz and 5KHz. Observe the resistor signatures in the following figures do not change as F_s changes.



$F_s = 20 \text{ Hz}$

$F_s = 60 \text{ Hz}$

$F_s = 1 \text{ KHz}$

$F_s = 5 \text{ KHz}$

Figure 6-5. Effect of Varying F_s on a 50 Ω Resistor Signature.

Shorts and Opens, Resistor Faults

Two of the most common faults that occur in electronic components and circuits are shorts and opens. A short circuit is typically a 0 Ω to 10 Ω low resistive path between two points in a component or circuit that normally would have a higher resistance between them. An open circuit is a break between two points in a component or circuit that prevents current from flowing.

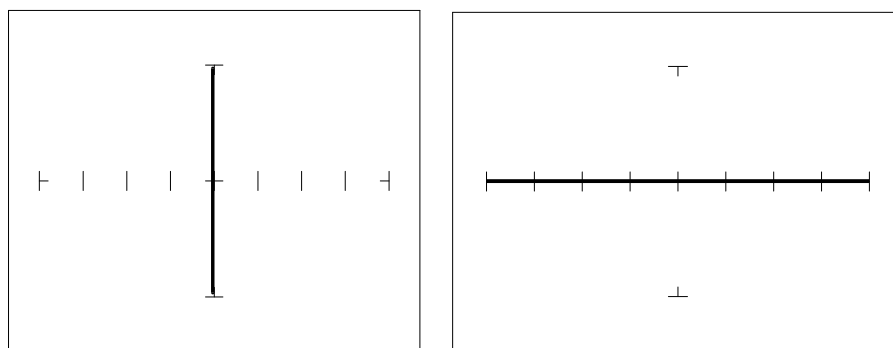

Short

Open

Figure 6-6. Short and Open Signature.

Review

- The signature of a purely resistive circuit is a straight line because the relationship between voltage and current in a purely resistive circuit is linear.
- This straight-line signature can vary from
 - completely horizontal (an open)
 - completely vertical (a short)
- As resistance increases
 - current decreases
 - the signature becomes more horizontal
- As the range increases
 - the volts per division of the horizontal axis increases
 - the internal resistance increases
 - the signature becomes more vertical

Applications

- The Access DH2 Tracker is a fast and efficient continuity tester, providing real time information.
- The Access DH2 Tracker will quickly locate resistor defects, shorts, opens and degradation that other testers cannot find.
- A majority of component failures are resistive in nature. This is important to remember; a component fault may only appear in one range because of the resistive nature of the fault.
- The Access DH2 Tracker's ability to determine the approximate fault resistance value greatly enhances the troubleshooting capability if the correct value is known.
- The Access DH2 Tracker can be used to adjust a potentiometer in circuit to an approximate operational setting. This application requires a known good board. Adjust each potentiometer on the board under repair to match the settings on a known good operational board. In most cases, the board under repair can now be powered up to an operational state where it can be adjusted to true specifications.

6-2 Capacitors

With a capacitor connected to the Access DH2 Tracker, the test signal across it responds quite differently than a resistor. The typical analog signature of a capacitor is an elliptical or circular pattern due to the fact that relationship between the test signal's current and voltage are non-linear. The current's waveform is 90 degrees out of phase with respect to the voltage. The diagram below illustrates this basic principle for capacitors.

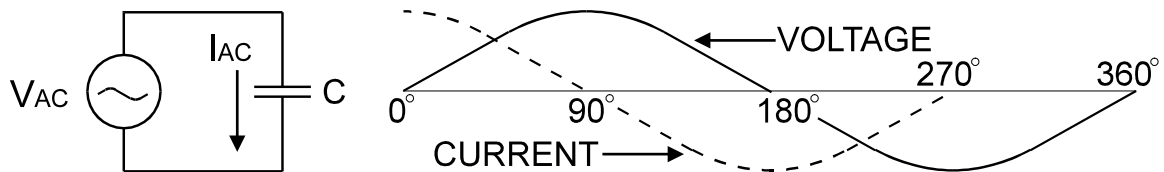

Figure 6-7. Capacitor Circuit with Test Signal's Current and Voltage Waveforms.

As the test signal's voltage crosses zero volts and becomes more positive, the current flowing in the circuit is at its maximum and becoming smaller. By the time the voltage has reached its maximum value, the current in the circuit has ceased flowing. As the voltage begins decreasing toward zero, the current begins increasing toward maximum. When the voltage reaches zero, the current is at its maximum value. Similarly, this same pattern follows as the voltage goes negative.

Because the current is at its maximum value when the voltage is at zero, the current leads the voltage. This is called phase shift and in a purely capacitive circuit, this phase shift equals 90° . On the Access DH2 Tracker, this analog signature appears as a circular waveform. The actual shape and slope of the elliptical signature depends on the capacitance and impedance value of the component and the test signal's voltage, internal resistance and frequency.

Capacitor Analog Signatures

The goal of this part is to explore some capacitive signatures and to help you understand how capacitor signatures are related to:

- The capacitance (μf) of the circuit under test
- The frequency (F_s) of the test signal
- The voltage (V_s) of the test signal
- The internal resistance (R_s) of the Access DH2 Tracker

Plug the red test microprobe in the Channel A jack, and the black test clip lead in the Common jack.



The device to be tested must have all power turned off and have all high voltage capacitors discharged before connecting the Access DH2 Tracker to the device.

Do the following to display the analog signature of a capacitor:

1. Select the 10V, 50Ω and 60Hz range
2. Place or clip a test lead on the opposite ends of a capacitor and observe the signature.

Signatures of Capacitors

The figure below shows analog signatures for four different value capacitors, 1000 μf, 100 μf, 10 μf and 1 μf. Select 10V, 50Ω and 60Hz.

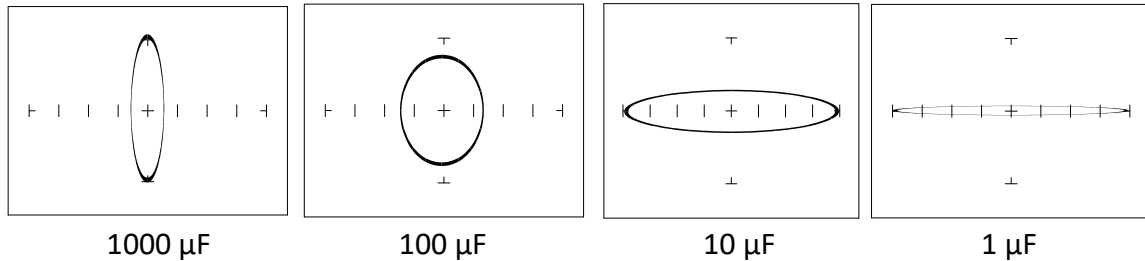

Figure 6-8. Signatures Of 4 Capacitors In 10V, 50Ω and 60Hz Range.

Note that as the capacitance values decrease, each signature changes from a vertical elliptical pattern to a horizontal elliptical pattern. In ASA, a large value capacitor has a signature that looks similar to a short circuit. And likewise, a small value capacitor has a signature that's similar to an open circuit.

Effect of Frequency (F_s) on the Signature of a 10 μF Capacitor

Select 10V, 50Ω and 20Hz. Then select 60Hz, 500Hz and 5KHz.

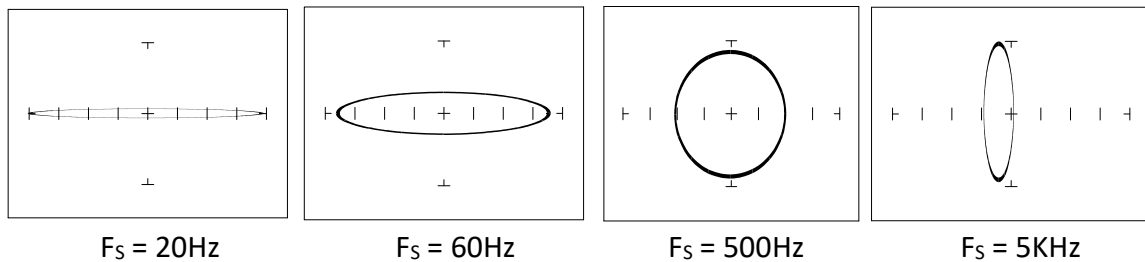

Figure 6-9. Signatures of A 10μF Capacitor at Different Frequencies

Note that as the test signal frequency increases, the 10 μf capacitor's signature changes from a horizontal elliptical pattern to a vertical elliptical pattern. In ASA, a capacitor at a lower test frequency, has a signature that looks similar to an open circuit. And likewise, the same capacitor at a high frequency has a signature that's similar to a short circuit.

Effect of Frequency (F_s) on the Signature of a 0.1 μF Capacitor

Select 10V, 1K Ω and 20Hz. Then select 60Hz, 500Hz and 5KHz.

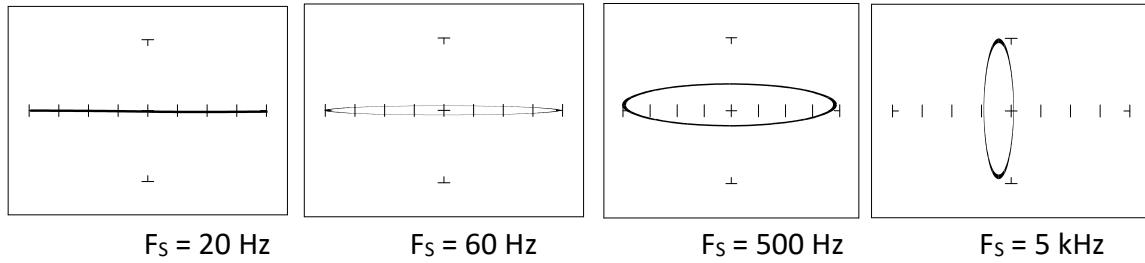

Figure 6-10. Signatures of A 0.1 μF Capacitor at Different Frequencies.

Note that as the test signal frequency increases, each signature changes from a horizontal elliptical pattern to a vertical elliptical pattern. In ASA, a small value capacitor at a lower test frequency has a signature that looks similar to a short circuit. And likewise, a small value capacitor at a higher test frequency has a signature that's similar to an open circuit. The signature of the 0.1 μF capacitor is similar to the 10 μF capacitor in shape but not in size due to the differences in their value.

Effect of Voltage (V_s) on the Signature of a 1 μF Capacitor

Select 200mV, 20K Ω and 60Hz. Then select 5V, 15V and 20V.

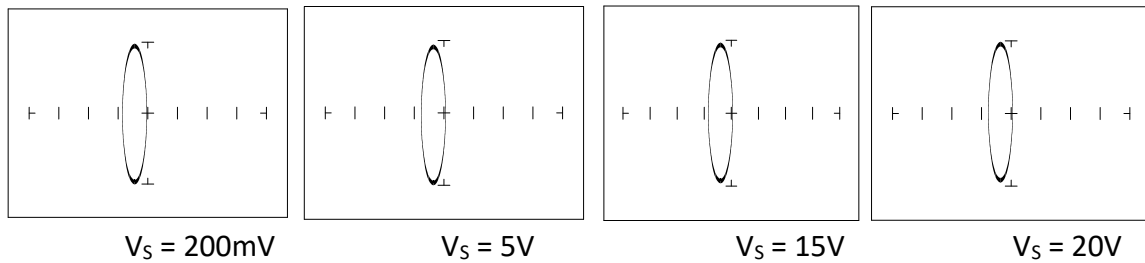

Figure 6-11. Signatures of A 1 μF Capacitor at Different Test Signal Voltages.

As V_s , the test signal voltage increases from low to high, the signatures did not change.

Effect of Resistance (R_s) on the Signature of a 1 μF Capacitor

Select 15V, 1K and 60Hz. Then select 5K, 20K and 100K.

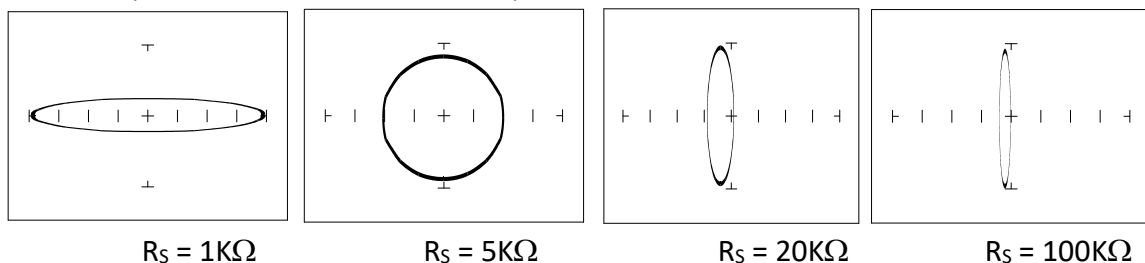

Figure 6-12. Signatures of A 1 μF Capacitor at Different Internal Resistances.

As the Access DH2 Tracker's internal resistance R_s decreased, the capacitor's signature changes from a horizontal elliptical pattern to a vertical elliptical pattern. In ASA, a large

internal resistance value results in a capacitor signature that looks similar to an open circuit. And likewise, a small internal resistance value results in a capacitor signature that's similar to a short circuit.

Understanding Capacitor Analog Signatures

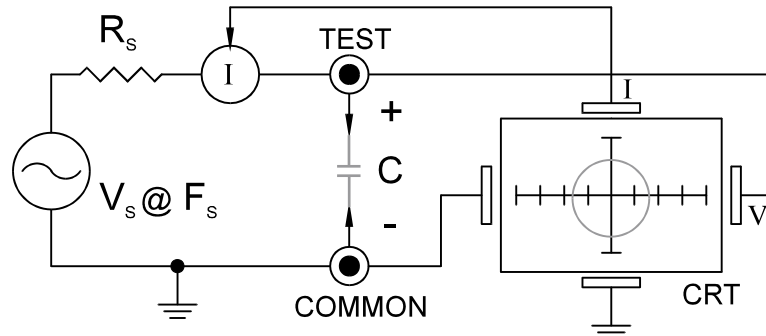

Figure 6-13. Access DH2 Tracker Core Circuit Block Diagram with a Capacitor.

The Huntron Workstation Software displays the Access DH2 Tracker signature as a response to its test signal, an analog signature that represents the relationship between voltage, current and resistance of a component. For circuits that contain capacitors, the effective resistance is called capacitive reactance, X_C . The mathematical formula is:

$$X_C = \frac{1}{2\pi fC}$$

X_C is inversely related to both capacitance and frequency. So to review and summarize capacitive analog signatures up to this point:

- Changing capacitance: As the capacitance of a circuit increases, the capacitive reactance X_C decreases. This means that when capacitance increases, the amount of current in the component or circuit will increase. On the Access DH2 Tracker, the elliptical signature will become increasingly vertical that implies more current flow.
- Changing frequency F_s : As the frequency of the test signal increases, the capacitive reactance X_C will decrease and the amount of current in the circuit will increase. On the Access DH2 Tracker, the elliptical signature will become increasingly vertical that implies more current flow.
- Changing voltage V_s : As the test signal voltage is changed from 200 mV to 20 V, the following occurs:
 - X_C of the capacitor is not affected
 - The applied V increases
 - The elliptical signature is not affected
- Changing source resistance R_s : As the resistance is changed from 1 k Ω to 100 k Ω , the following occurs:
 - X_C of the capacitor is not affected

- V_S increases so current decreases proportionately
- The elliptical signature becomes increasingly vertical

The figure above shows how the three variable parameters affect the capacitive signature. Frequency F_S and internal resistance R_S has the greatest affect, while increasing voltage V_S has no affect.

Table 3-1 shows the Access DH2 Tracker's limits for the minimum and maximum capacitance values it can handle.

R_s	$F_s = 20 \text{ Hz.}$	$F_s = 5 \text{ kHz}$
100 k Ω	0.01 μF - 1 μF	100 pF - 0.01 μF
10 Ω	20,000 μF - 100 μF	0.1 μF - 100 μF

Table 6-1. Access DH2 Tracker Minimum and Maximum Capacitor Values.

Capacitor Leakage Failures

One common physical failure in capacitors is dielectric leakage. The dielectric or insulator in a capacitor normally acts as a non-conductor between the capacitor's two plates. A flawed capacitor develops a conductive or leakage path between its two plates. This can be thought of as a resistance in parallel with the capacitance when observing its analog signature. The following examples show what some capacitor leakage problems may look like in the Access DH2 Tracker signature display with 50 Ω , 10V and 60Hz selected.

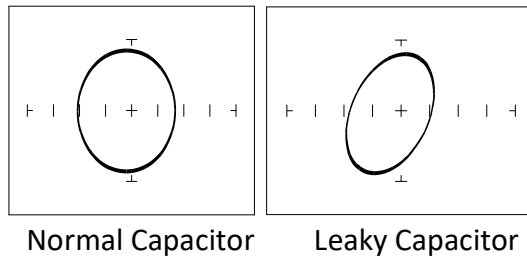

Figure 6-15. Signatures of A 100 μF Capacitor with Dielectric Leakage.

This example only simulates the leakage flaw by adding a 100 Ω resistor in parallel to a 100 μF capacitor. It shows the signature change from a normal circular ellipse pattern to a sloped and depressed vertical pattern. The signature of a real capacitive leakage would be quite similar to this example.

Another example of capacitive leakage is shown for a 10 μF capacitor.

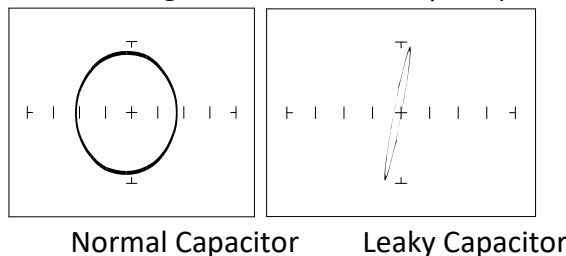

Figure 6-16. Signatures of A 10 μF Capacitor with Dielectric Leakage at 10V, 500 Ω , 60Hz

Again, this example only simulates the leakage flaw by adding a $68\ \Omega$ resistor in parallel to a $10\ \mu\text{F}$ capacitor. It shows the signature change from a normal circular ellipse pattern to a sloped and depressed vertical pattern. The signature of a real capacitive leakage would be quite similar to this example.

As you can see from the two previous examples, adding resistance in parallel to a capacitor distorts the normal signature with a diagonal bend to it. This is our first look at a composite signature, the kind of signature the Access DH2 Tracker displays when there are several components connected together in a circuit.

Review

- Capacitors have elliptical signatures due to the current and voltage phase shift.
- As the test signal's frequency increases, the capacitor's signature becomes more vertical due to decreasing X_C of the component.
- Capacitors with leakage flaws have their ellipses tilted diagonally due to an internal resistance in parallel with the capacitance.

Applications

- The Access DH2 Tracker can locate defective capacitors in or out of circuit. The ranges cover $10\ \text{pF}$ to $20,000\ \mu\text{F}$.
- When analyzing a capacitor's signature, adjust the Access DH2 Tracker's R_S and F_S for the most pronounced ellipse.
- The test signal frequency F_S can be changed to enhance a composite signature by emphasizing or de-emphasizing the capacitance.
- Besides resistance, faulty capacitor signatures often exhibit other irregularities such as non-symmetry, broken or distorted ellipse and saw-toothed shapes that can be seen in the signature display.

6-3 Inductors

Inductors, like capacitors, have elliptical analog signatures and respond to Access DH2 Tracker's test signal non-linearly. Also, like capacitors, an inductor's reactance (resistance to an AC test signal) is dependent on the test signal's frequency. Because of the way they are constructed using wire with some amount of resistance in it, it is hard to find a pure inductance. An inductor's analog signature will usually be an elliptical pattern with some slope or tilt to it due to the resistance of the coil wire.

Inductor Analog Signature

The goal of this section is to explore some inductive signatures and to help you understand how inductor signatures are related to:

- The inductance (L μ H) of the circuit under test
- The frequency (F_s) of the test signal
- The voltage (V_s) of the test signal
- The internal resistance (R_s) of the Access DH2 Tracker

Plug the red test microprobe in the Channel A jack, and the black test clip lead in the Common jack.

Do the following to display the analog signature of an inductor:

1. Select 50 Ω , 10V and 60Hz range (LOW Range)
2. Place or clip each test lead on the opposite ends of an inductor and observe the signature in the Access DH2 Tracker signature display.

Signatures of Inductors in 50 Ω , 10V and 2KHz

The figure below shows analog signatures for four different value inductors, 12,000 μ H, 1200 μ H, 120 μ H and 12 μ H. Select 10V, 50 Ω , 2KHz.

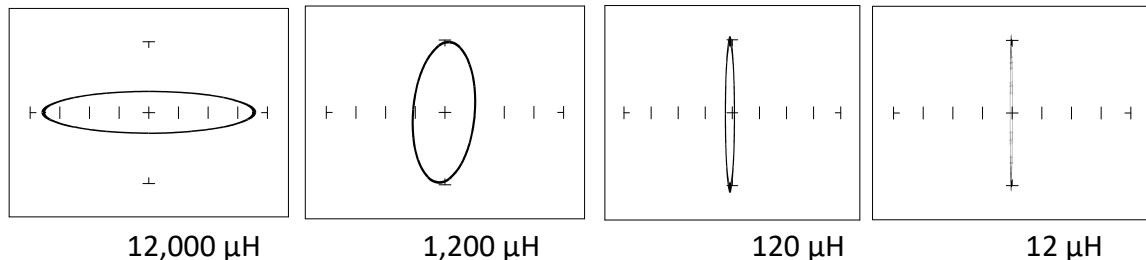
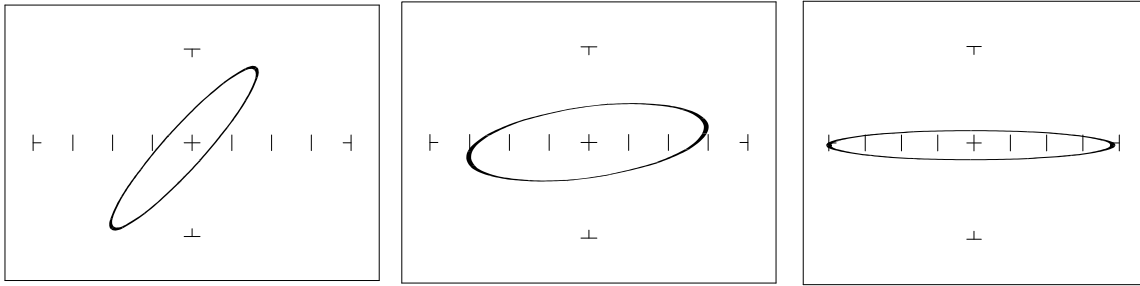

Figure 6-17. Signatures of 4 Inductors at 10 V, 50 Ω , 2KHz.

Note that as the inductance values decrease, each signature changes from a horizontal elliptical pattern to a vertical elliptical pattern. In ASA, a large value inductor has a signature that looks similar to an open circuit. And likewise, a small value inductor has a signature that's similar to a short circuit.

Effect of Frequency (F_s) on Inductor Signatures

Select 10V, 50 Ω , 60Hz. Then Select 1KHz and 5KHz.



$F_s = 60 \text{ Hz}$

$F_s = 1\text{KHz}$

$F_s = 5\text{KHz}$

Figure 6-18. Effect of Varying F_s on 12,000 μH Inductor Signatures.

Note that the signature changes from a vertical position to a horizontal position as the frequency increases. This means the resistance of an inductor increases as frequency increases.

Effect of Voltage (V_s) on Inductor Signatures

Select 200mV, 50 Ω , 60Hz. Then Select 5V and 10V.

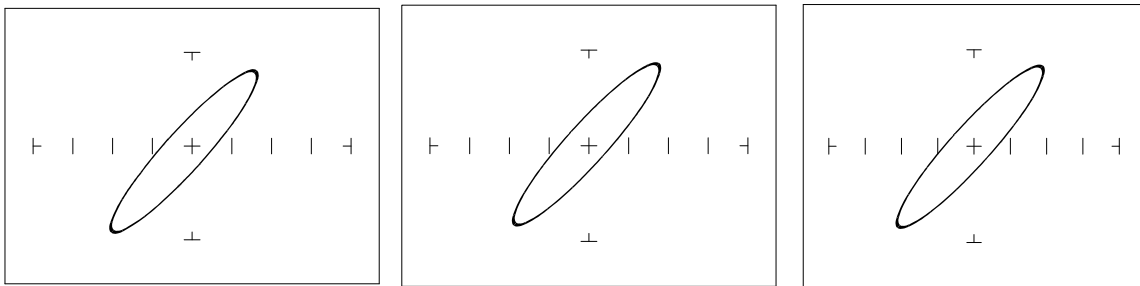

$V_s = 200 \text{ mV}$

$V_s = 5 \text{ V}$

$V_s = 10 \text{ V}$

Figure 6-19. Effect of Varying V_s on 12,000 μH Inductor Signatures.

Note that the signature does not change at the three test signal voltages. This means that the inductor's resistance is not affected by changes in the test voltage.

Effect of Internal Resistance (R_S) on Inductor Signatures

Select 2V, 10 Ω , 60Hz. Then Select 50 Ω and 200 Ω .

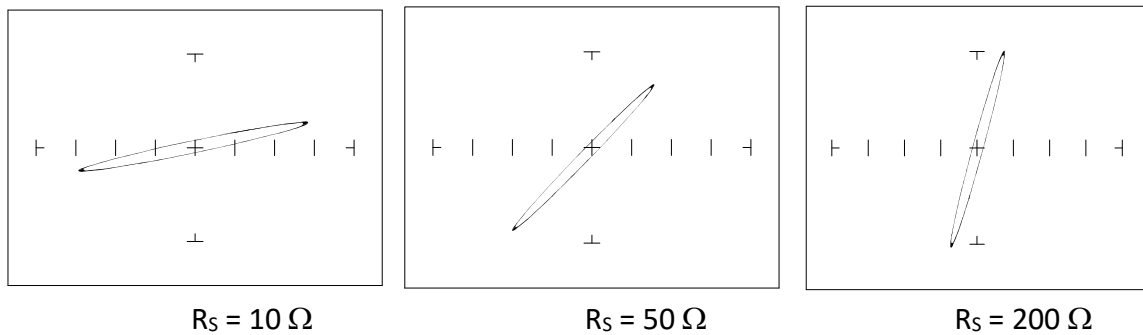

Figure 6-20. Effect of Varying R_S on 12,000 μH Inductor Signatures.

Note that the signature changes from a horizontal to a vertical position as the Access DH2 Tracker's internal resistance R_S increases. This means the inductor's resistance can be analyzed by matching it with the Access DH2 Tracker's test signal resistance.

Understanding Inductive Signatures

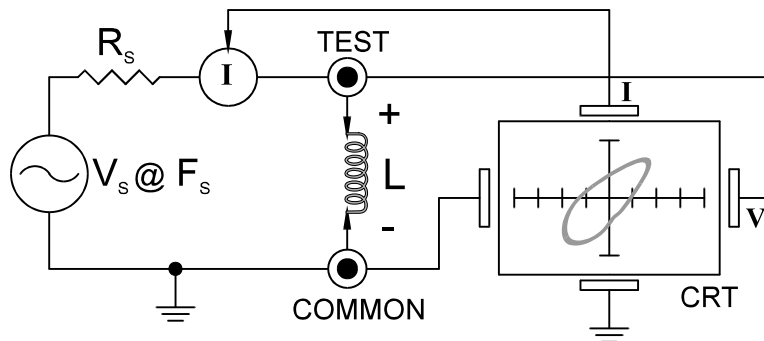

Figure 6-21. Access DH2 Tracker Core Circuit Block Diagram with an Inductor.

The Access DH2 Tracker's block diagram shows an inductor between the test terminals. The current is represented by the vertical axis and is derived as a series current that flows through Access DH2 Tracker's internal resistance, R_S . The voltage is represented by the horizontal axis and is derived as a voltage across the inductor.

The formula for the reactance X_L of an inductor is:

$$X_L = 2\pi fL$$

As the test signal frequency increases, the inductive reactance X_L becomes larger. As a result, the inductor's analog signature will change from a rounder elliptical to a flatter resistive type pattern. The size and shape of the ellipse depend on the inductor value, test signal frequency, and the selected resistance R_S .

Since inductors in reality are not pure inductors, the elliptical signatures they form on the Access DH2 Tracker display are usually distorted. Inductors constructed with a ferrite

core make the inductive characteristics different from those constructed without. The Access DH2 Tracker responds with a unique analog signature for each inductor type.

R_S	$F_S = 20 \text{ Hz.}$	$F_S = 5 \text{ kHz}$
100 k Ω	100H – 1000H	50mH – 1000mH
10 Ω	1H – 100H	1uH – 10mH

Table 6-2. Access DH2 Tracker Minimum and Maximum Inductor Values

Review

- Inductors display elliptical signatures similar to capacitors. Since the inductor also exhibits resistance, due to its construction, the ellipse may be distorted.
- As the Access DH2 Tracker test signal’s frequency is increased, the ellipse signature becomes flatter. This response is opposite to that of a capacitor.
- As the Access DH2 Tracker internal resistance R_S increases, an inductor's signature becomes more vertical (like the capacitor signature).
- When an inductor has a ferrite core, its signature distorts from a non-ferrite inductor’s ellipse.

Applications

- The Access DH2 Tracker is excellent for troubleshooting inductors. It can reveal shorted or open windings in large variety of inductive components.
- Components that are inductors or have inductive characteristics can be found in many real-world applications. For example, some of these are power transformers, relays, solenoids; fly backs, speakers, magnetic sensors, stepping motors and motor windings.
- The best technique for testing inductors is the comparison of a known good component's signature to a suspect component. For example, a motor armature has typically numerous windings so every winding should have a similar analog signature. This fact is true whether it's from an elevator or a tape deck. The armature of a DC motor can be tested by simply connecting to the motor brush leads and then adjusting the test range for the most pronounced or descriptive signature. Slowly turn the armature. Observe the Access DH2 Tracker’s signature display. This test will check continuity, the inductance and the condition of each brush contact without disassembling the motor.
- A computer switching power supply contains inductors. For example, a computer is reported “dead”. To make a quick diagnosis of the possible problem first make sure

the computer is disconnected from AC power. Then connect the red and black test probes across the prongs on the AC line cord going to the computer. Turn the computer power switch to the on position. If there is a response on the Access DH2 Tracker signature display, adjust the test range for the most pronounced inductive signature. Flick the power switch off and on and watch for noisy switch contacts. If there is no response, start by checking each component up to the primary winding of the transformer. With this technique, we have just verified the AC cord, the AC noise filter, the fuse, the power switch and the primary winding of the transformer, without removing the cover from the computer.

- Another simple test for a speaker or microphone is to apply the Access DH2 Tracker signal in $V_s = 10\text{ V}$, $R_s = 50\ \Omega$, $F_s = 60\text{Hz}$ range to the device input leads and listen for the 60 Hz tone or audible hum.
- To test solenoids, connect the test probes to the coil leads and manually move the plunger or activator in and out while observing if its signature changes.

6-4 Electromechanical Switching Components

Switches are electrical devices that either stop or allow current to flow in a circuit. They are either in an on or off state. Switching devices come in all types and sizes. There are simple mechanical switches, relays, optical switches, and many kinds of semiconductor switches. They are different because each uses a different kind of stimulus to turn them on or off. Because there are so many kinds of switching devices, there is no single testing procedure that will test them all completely. With the Access DH2 Tracker, the test signal can be setup so that the switch's analog signature will verify its switching function. The goal of this section is to develop a test strategy using ASA to test the switching function. This is not a complete test, but it will be enough to determine whether or not the device is functioning as a switch.

Manually Operated Mechanical Switches

A mechanical switch has two states: it is either open or closed. When open, no current can flow; when closed, it acts as a short and allows current to flow. The Access DH2 Tracker can test the switching function of mechanically activated switches easily. Unlike the DVM that samples and gives a continuity measurement, the Access DH2 Tracker displays real time activity so if a switch has noisy, resistive or intermittent operation, its analog signature on Access DH2 Tracker's display will reflect these conditions.

Plug the red test microprobe in the Channel A jack, and the black test clip lead in the Common jack.

Do the following to display the analog signature of a mechanical switch:

1. Select the $V_S = 10\text{ V}$, $R_S = 50\Omega$, $F_S = 60\text{ Hz}$ range button.
2. Place or clip each test lead to the switch leads and observe its signature on the Access DH2 Tracker signature display.
3. Turn the switch to its on or off position.

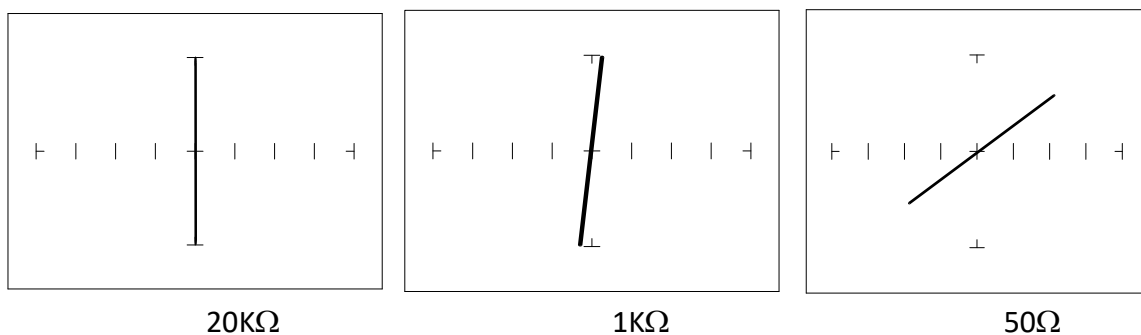

Figure 6-23. Signatures of a Pressed Keyboard Pushbutton Conductive Elastomer Switch. Note that as the ranges change from 20KΩ to 1KΩ to 50Ω, the signature tilts away from the vertical. This characteristic is similar to other components with internal resistance.

Review

- The switch has internal resistance.

- As the test signal's voltage decreases with each range change, the volts per division of the horizontal axis also decreases so that its analog signature becomes more pronounced. This is caused by the small voltage drop across the switch's internal resistance.

Electromechanical Relays

A relay is a switch that's activated by an electrical control input. The relay consists of switch contacts, magnets and an electromagnetic coil. The Access DH2 Tracker can test the coil part of the relay by looking at its inductive analog signature. **RELAY COIL TEST**
Do the following:

1. Select the $V_S = 10V$, $R_S = 50\Omega$, $F_S = 1KHz$ range.
2. Connect the black test lead from Access DH2 Tracker's Common jack to one side the relay coil (normally, the minus lead).
3. Connect the red test lead from Access DH2 Tracker's Signal jack to the other side of the relay coil (normally, the plus lead).

Observe the analog signatures of a magnetic reed type relay in the following figure.

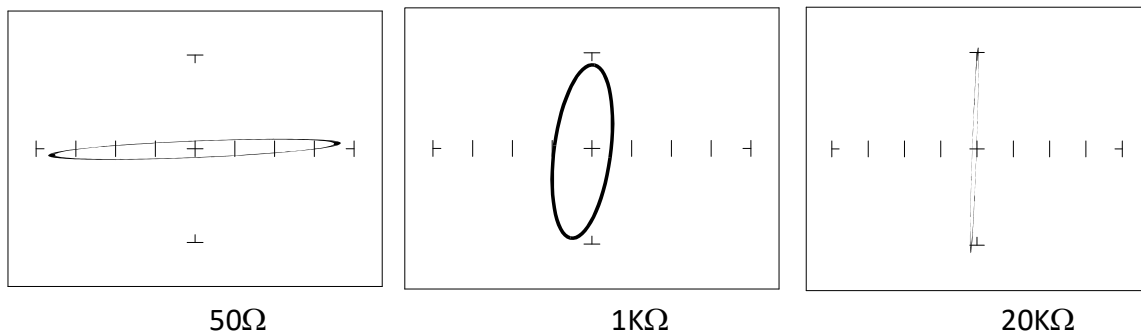

Figure 6-24. Signatures of a Magnetic Reed Relay Coil at 1KHz.

Note the characteristic inductive oval at 3 resistances. When applying Access DH2 Tracker's test signal to the coil, there may be an audible ringing sound generated from the relay under test from the switch contacts being excited.

Review

- The Access DH2 Tracker can test switches in real time. This makes an excellent test for micro switches, power switches, control switches, pressure and heat sensor switches.
- As the mechanical switch closes, watch for erratic or discontinuous signature. Switch bounce will display as multiple closure signatures. Resistive contacts will display a resistive signature at 50Ω.

SECTION 7 TESTING DISCRETE SEMICONDUCTORS

7-1. Diodes

The most basic type of solid state semiconductor component is the diode. Diodes are formed by creating a junction between p-type and n-type semiconductor material. The PN junction gives diodes and semiconductor components polarity characteristics that allow them to conduct current when an external voltage is applied. They conduct current in one direction, but not in the other. Current flows in a diode when the positive terminal (anode) is made more positive than the negative terminal (cathode). Figure 5-1 shows how the diode symbol indicates the polarity of the diode.

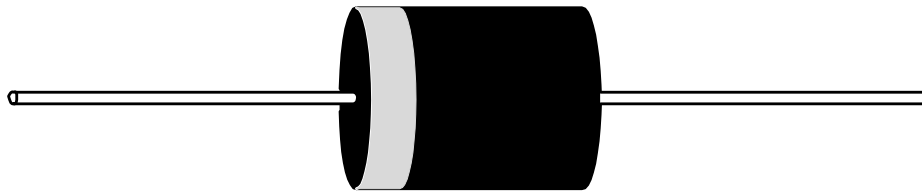

Figure 7-1. Diode and Schematic Symbol.

Diode Analog Signatures

Diode signatures demonstrate the fundamental operation of a semiconductor junction. There is a threshold or forward voltage V_F (about 0.6V for a silicon diode) at which the diode begins to conduct current. The diode acts as an open circuit and no current flows as long as the voltage differential between the anode and cathode is below that threshold. As the anode to cathode voltage becomes more positive, the diode will begin to conduct current. Once current begins to flow in the diode, very small increases in anode voltage will cause very large increases in current. In analog signature analysis, this is called the “knee” effect in which is characteristic of a good semiconductor junction.

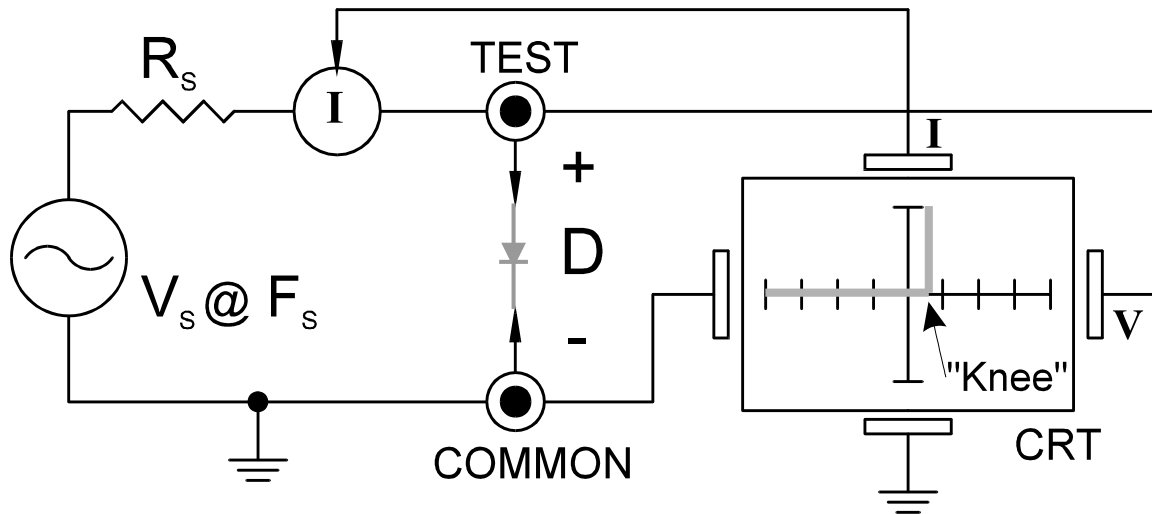

Figure 7-2. Access DH2 Tracker Core Circuit Block Diagram with a Diode.

You can see this "knee" signature on some diodes in the next section.

Do the following to display the analog signature of a diode:

1. Select 50 Ω , 10V and 60Hz.
2. Place or clip the red test lead from the Access DH2 Tracker's Channel A jack to anode lead of the diode.
3. Place or clip the black test lead from the Access DH2 Tracker's Common jack to anode lead of the diode.

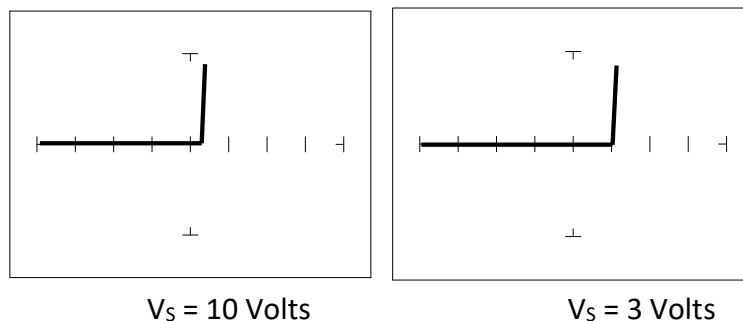

Figure 7-3. Signatures of a 1N914 type Silicon Diode at 50 Ω and 60Hz.

The diode signatures are similar to each other. In the 50 Ohm range, the test signal voltage is 10 V_p. Each horizontal division on the display equals approximately 2.5V. In this range the diode's signature shows that its threshold or forward voltage is approximately 0.6 Volts. By lowering the test voltage to 3V with the encoder, the 0.6V threshold is clearly visible for easier analysis.

Effects of Frequency (F_s) on Diode Signatures

With the 3V, 50 Ω selected and the test signal frequency of 60 Hz, the signature of the diode is shown on the left figure below. Changing only the test signal frequency to 5 kHz displays the signature on the right. At $F_s = 5$ kHz, the diode's signature has slight circular loop added to it. This loop in the signature is due to a physical characteristic of diodes called junction capacitance.

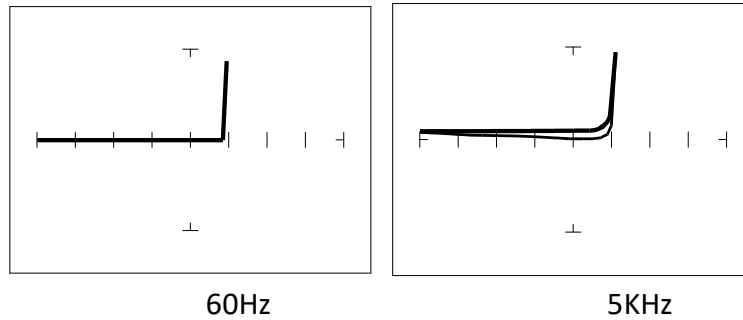

Figure 7-4. Signature of A 1N914 Diode at Different Frequencies at 3V and 50 Ω .

Effects of Internal Resistance (R_s) on Diode Signatures

Changing Access DH2 Tracker's internal resistance R_s moves the vertical knee portion of the diode's analog signature. As R_s increases, the knee of the signature moves inward toward the origin. R_s controls the current that's flowing through the diode so the forward diode voltage changes in response to the current change.

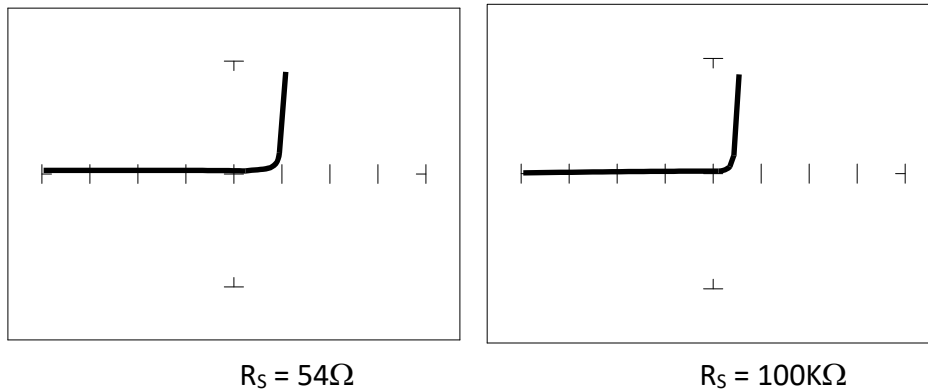

Figure 7-5. Signature of A 1N914 Diode at Different Resistances at 3V and 60Hz.

Composite Diode Signatures

A composite analog signature is a combination of several components connected together in an electronic circuit. Up to this point, we have been showing you what the basic component signatures look like out of circuit. In the real world of electronics troubleshooting, components are connected together in a circuit and when testing with ASA, the signatures are a composite that may appear quite complex. However, with knowledge of ASA fundamentals and experience you will find that even the most complex looking signatures can be analyzed quickly and efficiently. This section will introduce you to some examples of composite diode signatures.

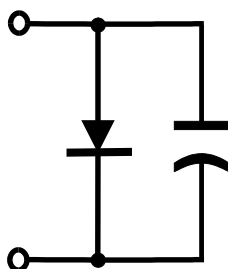

Figure 7-7. Composite Model of a Diode and Capacitor in Parallel.

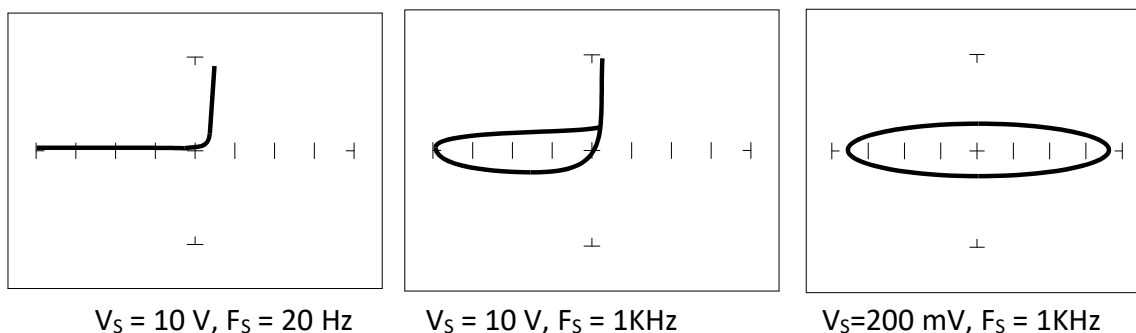

Figure 7-8. Composite Signature - 1N914 Diode and 1µF Capacitor in Parallel.

The signature on the left shows only the diode signature because the test signal frequency is set below any visible contribution due to the capacitive reactance. The composite signature in the center consists of the distinctive loop of the capacitor and the "knee" pattern of the diode. The signature on the right shows only the capacitor signature because the test signal voltage is below the diode's turn on level. When multiple components are connected together, it's important to realize that the Access DH2 Tracker has the ability to selectively display the signature of a single component.

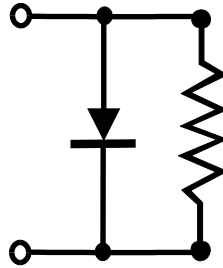

Figure 7-9. Composite Model of a Diode and Resistor in Parallel.

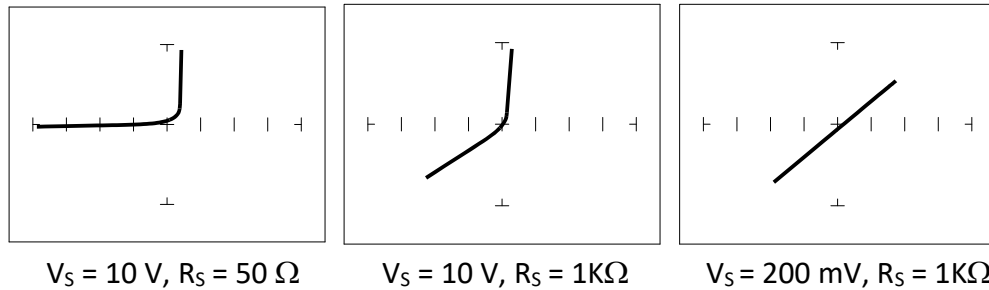

Figure 7-10. Composite Signature - 1N914 Diode and 1.5KΩ Resistor in Parallel.

The signature on the left shows only the diode signature because the test signal resistance is set below any visible contribution due the 1.5 kΩ resistor. The composite signature in the center consists of the distinctive slope of the resistor and the "knee" pattern of the diode. The signature on the right shows only the resistor signature because the test signal voltage is below the diode's turn on level. Again, when multiple components are connected together, it's important to realize that the Access DH2 Tracker has the ability to selectively display the signature of a single component.

Diode Failures

Diodes can fail in a number of ways, and each type of failure will cause the signature to change. The defective diodes often appear as open and short signatures. Two other types of flaws are internal resistance and leakage.

Internal Resistance Flaw in a Diode

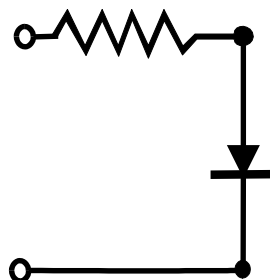
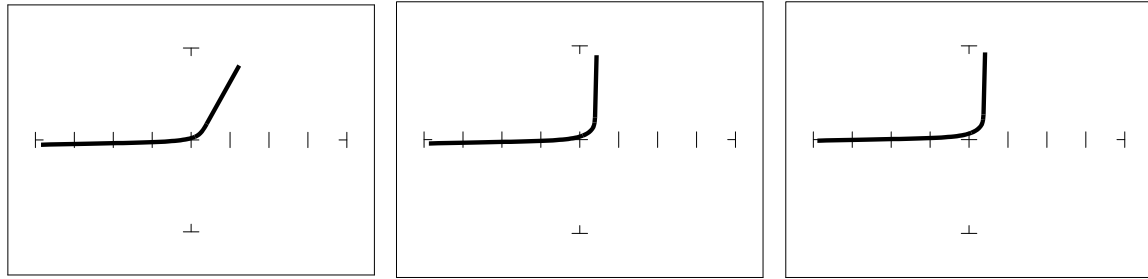

Figure 7-11. Defective Diode Model with a Small Series Resistor.



54Ω, 10V 1KΩ, 15V 20KΩ, 20V
 Figure 7-12. Defective Diode Signature with a 50 Ω Series Resistor.

The LOW range shows that there is a resistive component to the signature when the diode is conducting. This is the result of a defect in the diode's internal PN junction. The resistance is visible only in LOW range because the voltage-drop across it is small. In the other two ranges, the resistance is masked due to the internal resistances being too large to show such a small voltage drop.

Internal Leakage in a Diode

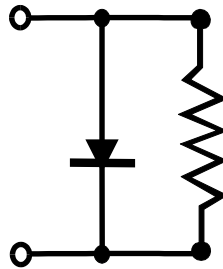

Figure 7-13. Defective Diode Model with an Internal Leakage Resistance.

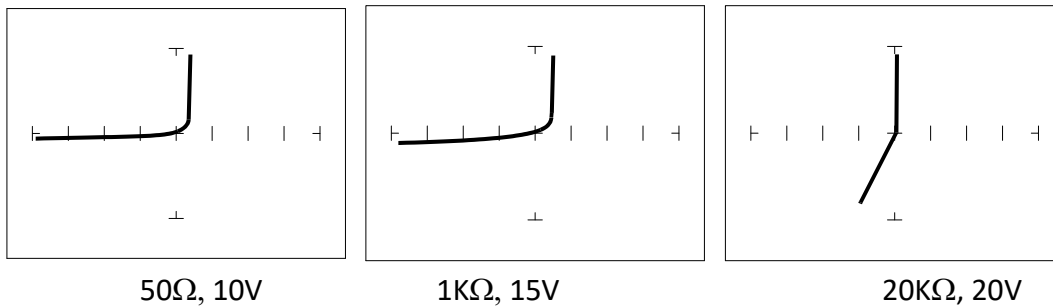

Figure 7-14. Signature of a 1N914Diode with Internal Leakage (10KΩ in Parallel).

Notice that in the 50Ω range, there does not seem to be a problem. In both medium ranges, you can see the diode conducting when it should be acting like an open. This is called leakage. The diode acts like a diode when it is forward biased. When reverse biased, the diode acts like a resistor when it should be acting as an open.

Zener Diodes

Normal switching and signal diodes conduct when forward biased only. When reverse biased, they act as opens unless they are operated outside design limits. If this condition occurs then so much voltage is applied that they break down and can no longer prevent current flow.

A Zener diode is a different type of diode and is designed for operation when reverse biased (diode's cathode connected to positive and anode to negative), but under carefully controlled conditions. When the Zener diode is forward biased (diode's cathode connected to negative and anode connected to positive), they act as regular diodes and begin to conduct at approximately 0.6V.

When reverse biased, they act as an open until the applied voltage reaches their specified Zener voltage, at which time the Zener diode begins to conduct current. Even if the reverse voltage is increased, the voltage across the Zener remains constant. It is this feature of Zener diodes that allows them to be used as voltage regulators and references. Because they conduct in both directions, the Zener diode's analog signature has two knees, one at 0.6V and the other at the Zener voltage of the diode. In ASA terminology, this two-knee signature is known as the classic "chair" pattern that is common in many solid state semiconductor components.

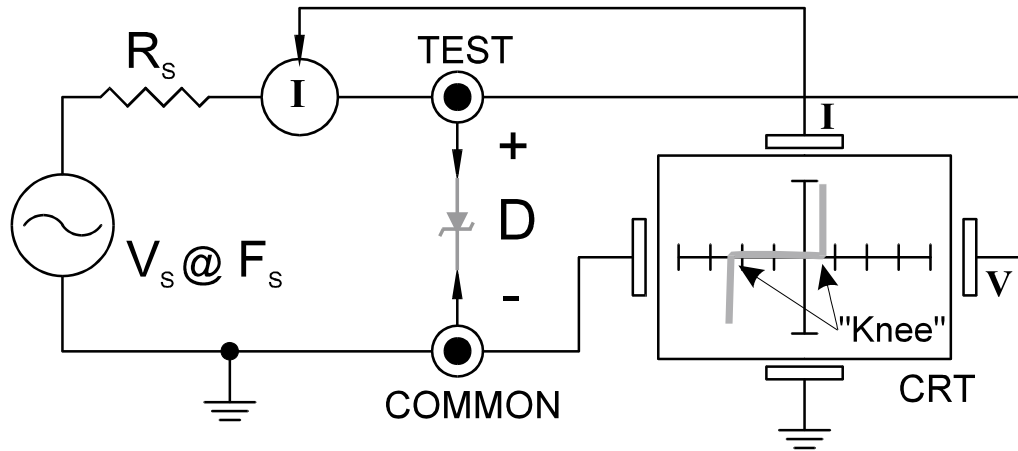

Figure 7-15. Access DH2 Tracker Core Circuit Block Diagram with a Zener Diode.

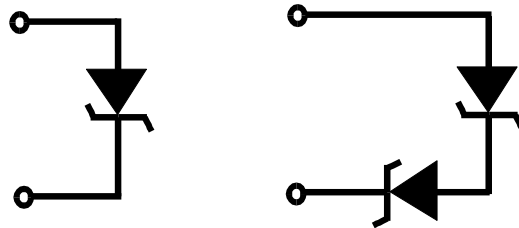
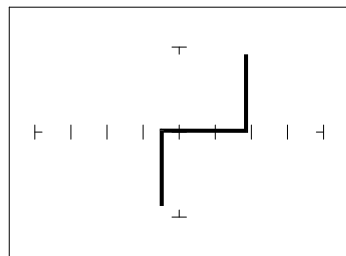
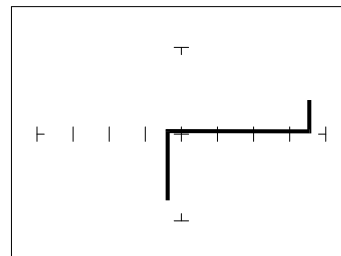

Figure 7-16. Single Zener Diode and 2 Zener Diodes in Series.



Single 1N5239B Zener Diode



2 Zener Diodes in Series, 1N5239B

Figure 7-17. Signatures of Zener Diodes at 20V, 20K Ω

Since each horizontal division on the Signature graticule (in 20V range) is approximately 5 Volts, from the signature on the left you can estimate that this is about a 9V Zener diode. The signature at the right is the signature of two Zener diodes connected in series. The Zener voltage (V_Z) of this circuit is the sum V_Z of each of the separate diodes. The signature shows this voltage to be approximately 18 Volts.

Review

- Diodes conduct current in one direction (forward biased) and not the other. The diode's analog signature displays this characteristic as the “knee” effect or pattern.
- Diodes have polarity, an anode and a cathode.
- Diode defects, other than opens and shorts, are usually resistive.
- A diode in series or parallel with a resistor or capacitor will create a composite signature displaying both characteristics. The Access DH2 Tracker makes it easier to separate these characteristics from composite signatures using the three parameters F_s , R_s and V_s .
- Zener diodes are special diodes that conduct when reverse biased at a specific voltage.

Applications

- Diode damage or degradation can appear as a loss of sharpness or rounding in the “knee”.
- While faulty diodes display resistive current and voltage legs, they are usually nonlinear or curved.
- The polarity of an unmarked diode can be determined by the orientation of the display with a known diode.
- The Access DH2 Tracker can be used to identify an unknown Zener diode. If the Zener diode is damaged, locate a good one, possibly on another board or in the same circuit and use the Access DH2 Tracker to approximate the voltage.
- Look for the Zener effect when checking voltage regulators such as the 7805. This can help determine an unknown or faulty device.
- The Access DH2 Tracker can be used to test and determine the four pin connections on a bridge rectifier, (AC1, AC2, + and -).

7-2 Transistors

A bipolar transistor is a three-layer device. There are two basic types. A PNP transistor has a layer of n-type silicon material sandwiched between two layers of p-type material. An NPN transistor has a layer of p-type silicon material sandwiched between two layers of n-type material. Figure 5-20 shows the relationship between type of material and circuit symbol for a PNP and an NPN transistor.

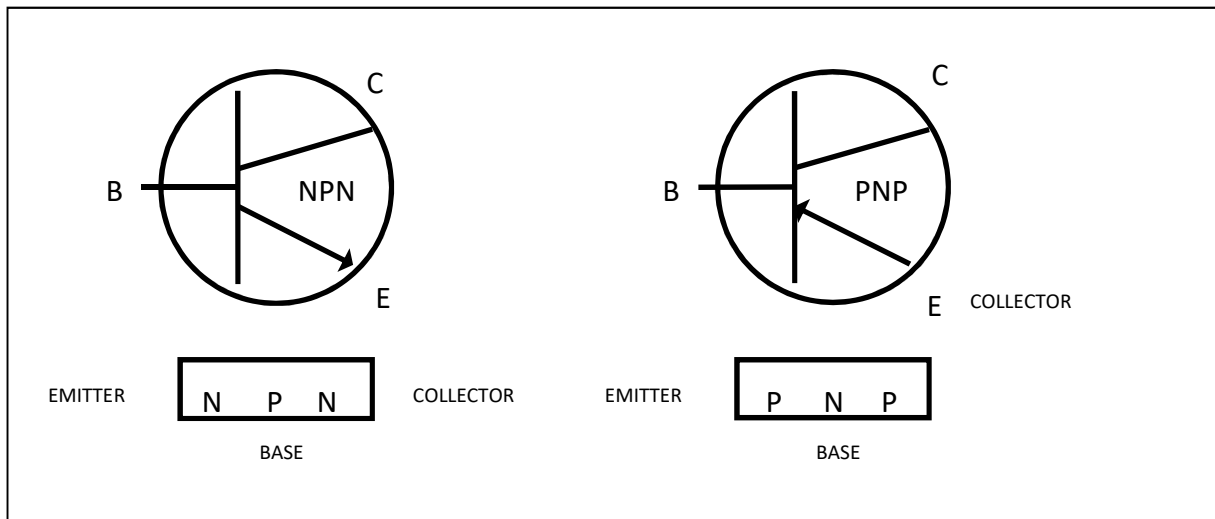

IMPORTANT NOTE

Use of this instrument may alter the current gain (h_{FE} or β) of a bipolar transistor whenever the emitter is tested. Either the base-emitter or collector-emitter test circuits satisfy this criterion. While heating of the device due to the current produced by the instrument may cause a temporary change in h_{FE} (most noticeable in the low range), a permanent shift in h_{FE} may occur whenever the base-emitter junction is forced into reverse breakdown (~6-20 Volts). If the voltage is above 6 Volts, then the magnitude of the shift depends on the duration of the test and the resistance selected. Reducing the voltage to 5 Volts or less will avoid this problem.

Most bipolar transistor circuit designers take into account a wide variation in h_{FE} as a normal occurrence and design the related circuitry to function properly over the expected range of h_{FE} . The effects mentioned above are for the most part much smaller than the normal device variation so that the use of this instrument will have no effect on the functionality of good devices and can fulfill its intended purpose of a means to locate faulty components. However, some circuits may depend on the h_{FE} of the particular part in use, e.g. instrumentation that is calibrated to certain h_{FE} value or precision differential amplifiers with matched transistors. In such instances, this instrument should not be used as its use may cause the h_{FE} to shift outside the limited range where calibration can correct for any change.

Suggestions to minimize effects on bipolar transistors:

1. Use 5 Volts or less for testing the base-emitter or collector-emitter.
2. If using 6 Volts or greater, then keep the duration of the test as short as possible.
3. Identify the base, emitter and collector pins of the device and then test the collector-base junction to determine whether it is an NPN or PNP. Since the emitter is not tested there will be no effect on h_{FE} regardless of the selected voltage.

Bipolar Transistor Signatures

In order to better understand the signatures that transistors create on the Access DH2 Tracker, we can model these devices in terms of equivalent diode circuits. These are shown in figure 5-21. These figures show that the collector-based junction analog signature looks similar to a diode signature, and the emitter-base junction signature looks similar to a Zener diode signature. Because we have already seen the signatures of these two types of junctions when we tested diodes, they should be familiar to you.

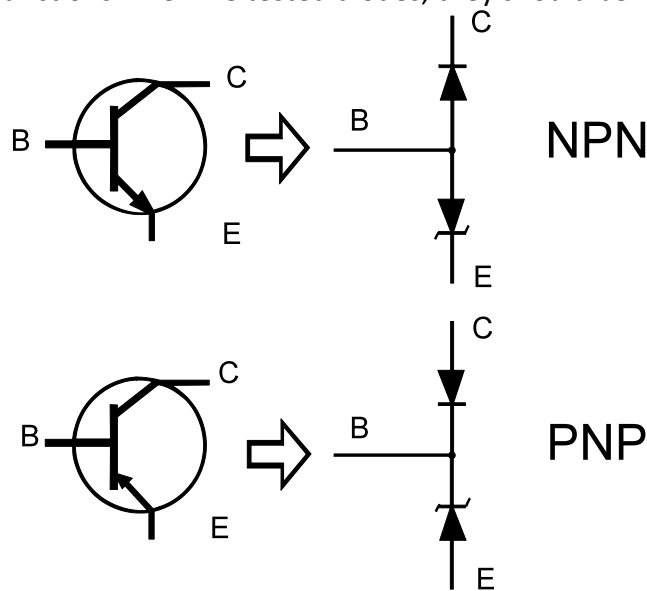

Figure 7-19. NPN And PNP Bipolar Transistor Equivalent Circuits

Bipolar Transistor Base-Collector Signatures

Do the following to display the analog signatures of a bipolar transistor:

1. Select the 1K Ω and 15V.
2. Place or clip the red test lead from the Access DH2 Tracker's Channel A jack to collector lead of the transistor.
3. Place or clip the black test lead from the Access DH2 Tracker's Common jack to base lead of the transistor.

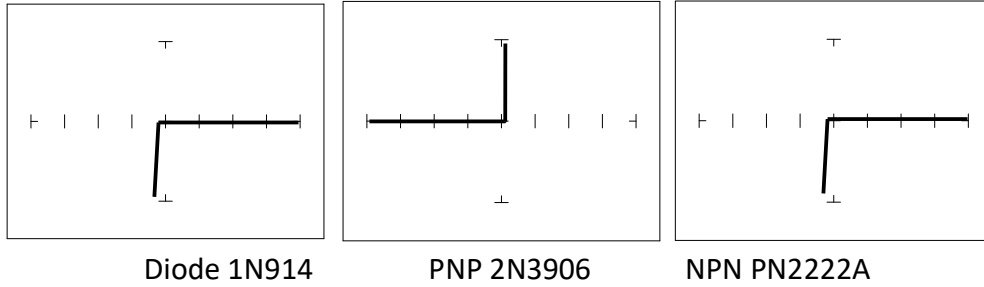

Figure 7-20. Signatures of a Diode and Collector-Base of Transistors at 1KΩ and 15V.

Notice that the collector-base signature of an NPN transistor is identical to the signature of diode. The collector-base signature of a PNP transistor, which has opposite polarity from a NPN, looks similar to a diode with its polarity reversed. These are the signatures we expected from our circuit modeling. We can do the same kind of comparison with the emitter-base circuits.

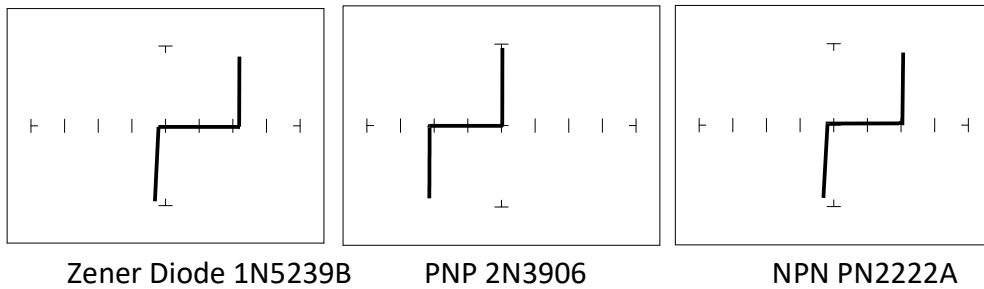

Figure 4-21. Signatures of a Diode and Emitter-Base of Transistors at 1KΩ and 15V.

We can see that the base-emitter signature of the NPN transistor is nearly identical to the signature of the Zener diode. The emitter-base signature of a PNP transistor is also nearly identical but opposite in polarity to the Zener diode.

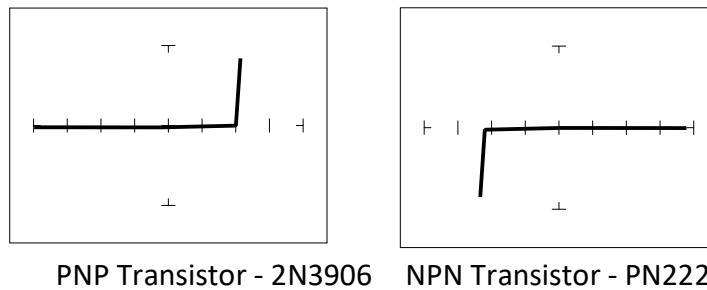

Figure 7-22. Signatures of the Collector-Emitter of Transistors at 1KΩ and 15V.

You can see that the collector-emitter signature of a PNP transistor looks like a forward biased diode with the knee at approximately +7 Volts. The collector-emitter signature of a NPN transistor looks similar to a reverse biased diode with the knee at approximately -7 Volts.

All bipolar junction transistors have essentially the same looking signatures.

Identifying Unknown Transistors

Sometimes, we need to identify unknown transistors. We may need to replace one in a circuit for which we do not have a schematic. The Access DH2 Tracker makes this a relatively simple procedure because each type of junction has a characteristic signature. This makes it possible to identify each of the terminals and the polarity of the transistor. Do the following:

1. Select 20V, 20K Ω and 60Hz.
2. Probe pin 1 with the red probe and pin 2 with the black probe.
3. Identify the signature.

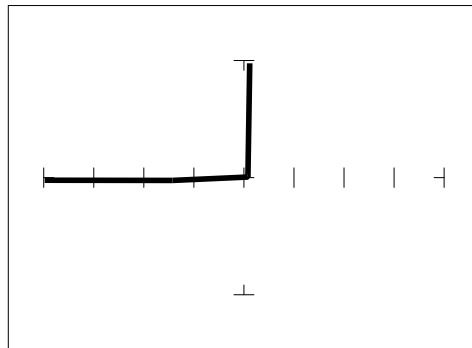

Figure 7-23. Signature of Pins 1 And 2 Of an Unknown Transistor.

4. This looks like a collector-base signature. What you do not know yet, is which pin is the collector and which pin is the base?
5. Probe pin 3 with the red probe and pin 2 with the black probe.
6. Identify the signature.
7. This looks like a collector-emitter signature.

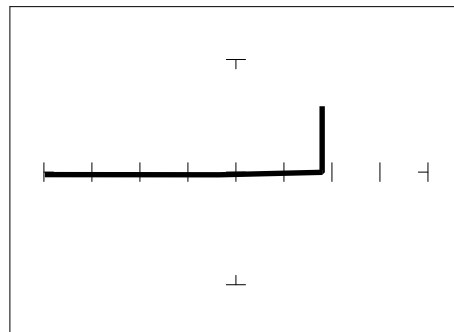

Figure 7-24. Signature of Pins 3 and 2 of an Unknown Transistor.

8. Now that you know that pin 2 of the unknown transistor is the collector. Place the black probe to the base on pin 1 and move the red probe to the emitter on pin 3. A base to emitter signature will be displayed. This transistor is a NPN type since the base-emitter signature matches a NPN transistor.

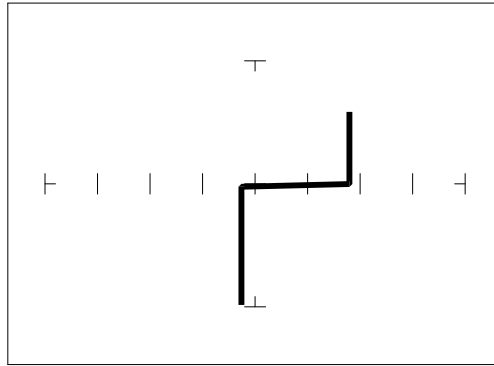

Figure 7-25. Signature of Pins 1 And 3 Of an Unknown Transistor.

Darlington Bipolar Transistor Signatures

The Darlington transistor is basically two transistors paired together in a special configuration. The emitter of the first transistor is connected to the base of the second transistor. The collectors of both transistors are connected together. The base of the first transistor serves as the external base lead and the emitter of the second transistor serves as the external emitter lead. A block diagram of a Darlington transistor and its analog signature are shown in the following figures.

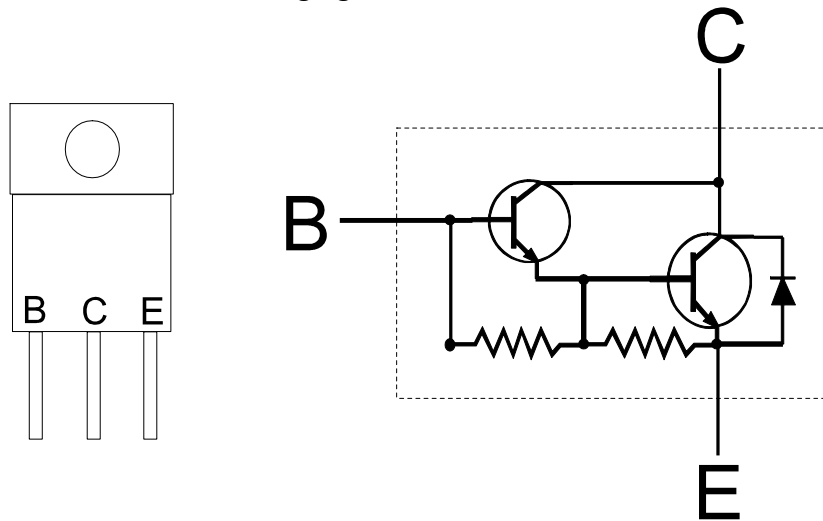

Figure 7-26. Diagram of a Darlington Transistor.

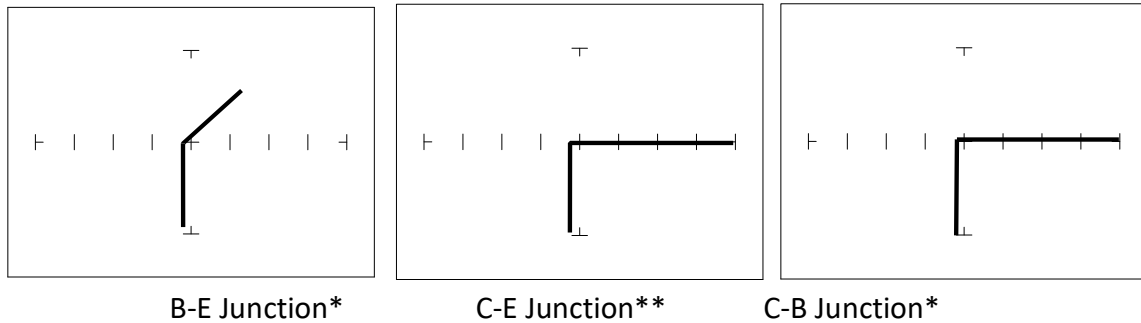

Figure 7-27. Signature of a Darlington Transistor, TIP112 NPN Type at 20V and 20K Ω .

Note that the B-E junction has a sloped leg bend in its signature caused by internal resistors R1 and R2.

Review

- A PNP bipolar transistor consists of a layer of N-type silicon sandwiched between two layers of P-type silicon.
- A NPN bipolar transistor consists of a layer of P-type silicon sandwiched between two layers of N-type silicon.
- To test a transistor, the base-emitter (B-E), collector-base (C-B) and collector-emitter (C-E) junctions all need to be examined.
- The transistor signature resembles the diode signatures previously examined. They have polarity and may exhibit the Zener effect.

Applications

- Transistors will display the same type of faulty signature as diodes, with a rounded “knee” and non-linear or resistive current and voltage legs.
- The Access DH2 Tracker can be used to determine the type of transistor; bipolar, Darlington, FET, etc.
- The Access DH2 Tracker can be used to identify the polarity of a transistor (PNP or NPN).
- The Access DH2 Tracker can be used to determine the base, collector and emitter on an unknown transistor.
- The Access DH2 Tracker can be used to match the gain (beta) of two transistors.
- The above techniques of identification are invaluable when repairing foreign electronics and systems without schematics.

7-3 Solid State Switching Components

Optical Switches

There are two types of optical switches: phototransistors and optocouplers. Phototransistors can be used in two modes depending on the application. It can be used as either a light activated transistor or as a light activated diode. In either mode, light is used to turn it on and allow current to flow.

An optocoupler consists of a light emitting diode and a phototransistor in the same package. They are electrically isolated. When the diode is turned on by an external signal, it radiates light. This light falls on the phototransistor base junction that results in the device turning on.

Phototransistor

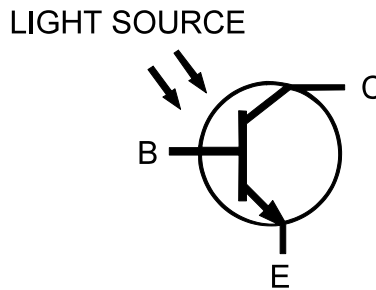
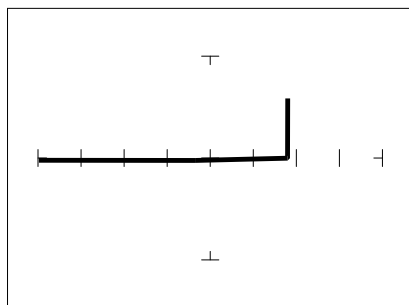

Figure 7-28. Phototransistor Schematic Diagram.

Do the following to display the analog signature of a phototransistor:

1. Select the 1K Ω and 15V.
2. Place or clip the red test lead from the Access DH2 Tracker's Channel A jack to collector lead of the component.
3. Place or clip the black test lead from the Access DH2 Tracker's Common jack to emitter lead of the component.



MRD3056 with No Light

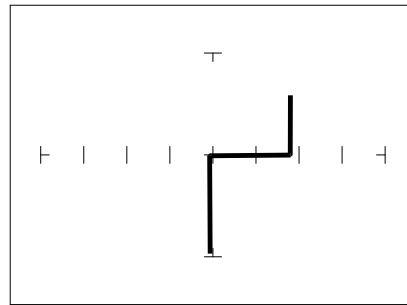

MRD3056 with Light

Figure 7-29. Signatures of an NPN C-E Junction Phototransistor at 15V and 1K Ω .

The phototransistor's signature is similar to a diode's signature in reverse breakdown mode when not activated by light and as a short signature when activated by a bright external light.

SCRs and TRIACs

A SCR and TRIAC are semiconductor components that are used in switching applications. A SCR (Silicon Controlled Rectifier) is used for DC switching circuits. A TRIAC is used for AC switching circuits. This section will demonstrate how to dynamically test these components.

Silicon Controlled Rectifiers (SCRs)

The SCR is a switching semiconductor device that conducts positive current only. Its symbol and equivalent circuit can be seen below. When the gate (G), is at the same voltage level as the cathode (K), the SCR acts like an open. When the gate (G), is forced more positive than the cathode (K), positive current flows between the anode (A) and the cathode (K).

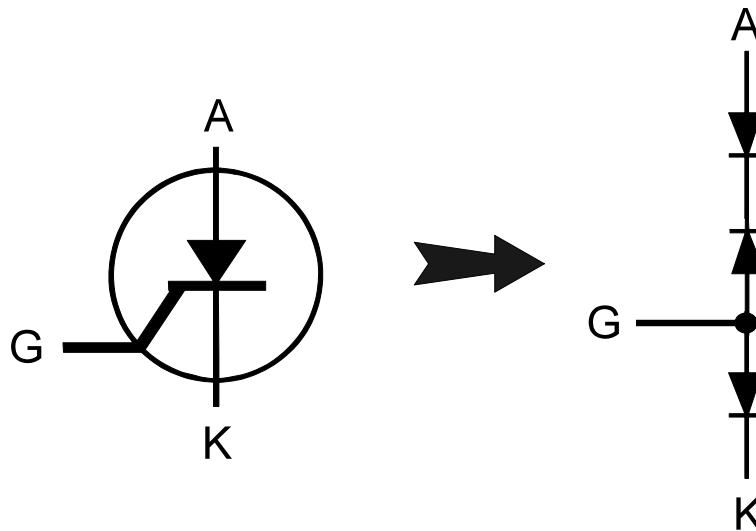

Figure 7-30. Diagram of a Silicon Controlled Rectifier.

Do the following to display the analog signature of a SCR:

1. Select the 20V, 20K Ω and 60Hz.
2. Place or clip the red test probe from the Access DH2 Tracker's Channel A jack to gate lead (G) of the component.
3. Observe the gate-anode signature of the SCR.
4. Move the black test probe from the SCR's anode lead to cathode lead (K) of the component.
5. Observe the gate-cathode signature of the SCR.

6. Place the red test probe to the SCR's anode lead and the black test probe to the SCR's cathode lead.
7. Observe the SCR's anode-gate signature.

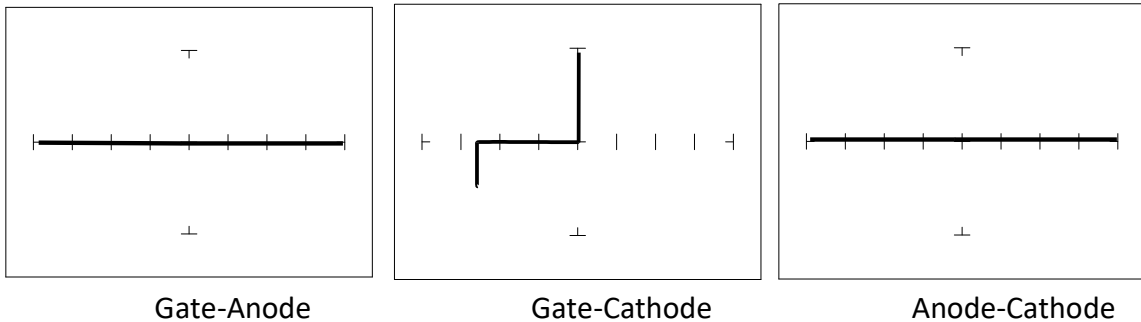

Figure 7-31. Signatures of A SCR - C106B Type at 20V and 20K Ω .

Review

- Solid state photosensitive switch components are turned on by light.
- SCRs and TRIACs are solid state switches that are turned on by a control input pin called a gate. SCRs conduct current in one direction while TRIACs conduct current in both directions.

Applications

- The SCR and TRIAC can also be a problem to troubleshoot. They may be used to switch large currents. Quite often these components are susceptible to degradation and eventual failure. The Access DH2 Tracker can easily show these failures.

SECTION 8 TESTING INTEGRATED CIRCUITS

8-1 *Digital Integrated Circuits*

Digital integrated circuit (IC) chips are made from transistors on a common substrate. Their analog signatures are typically variations of the discrete diode and transistor signatures. Most logic ICs, contain multiple circuits in one chip. These chips can have pins from 14 to over 200, although quite often many pins share quite similar signatures. This can make troubleshooting easier by giving us an easy-to-find signature to use as a comparison. In this section, it is important to understand how the Access DH2 Tracker and ASA respond to these circuits.

Integrated Circuit Failures

A functioning IC may stop working for a number of reasons. Some of the most common causes of IC failures are:

- EOS - Electrical Over Stress. The IC's maximum electrical specifications have been exceeded. This condition may result in the IC developing internal shorts and opens.
- ESD - Electrostatic Discharge. Repeated exposure may cause internal resistance to develop in the IC junctions. This internal resistance may vary from 5 k Ω to 25 k Ω with a typical value of 20 k Ω . ESD exposure can cause internal flaws such as resistance, opens and shorts.
- Dendrites - A process flaw, that results in particles growing between conductors on a substrate causing shorts.
- Ionic - Contamination introduced at the time of manufacturing that develops into leakage between substrate channels. This causes 5 k Ω to 25 k Ω of resistance.
- Purple Plague - Destructive interaction between gold and aluminum metal layers. Junction connections become very brittle and may cause internal opens.
- Corrosion or Electromigration - Another process flaw in which aluminum metallization causes pinholes, corrosion and resistance. This will create opens and resistance.

Digital Integrated Circuit Signatures

Before we examine the analog signatures of an IC, let's study the block diagram of a 74LS245 octal bi-directional bus buffer to introduce some basic concepts. This IC is a member of the low power Schottky transistor-transistor logic family (LSTTL). Examine the block diagram for this chip below. You will see that there are only four different kinds of circuits on this chip.

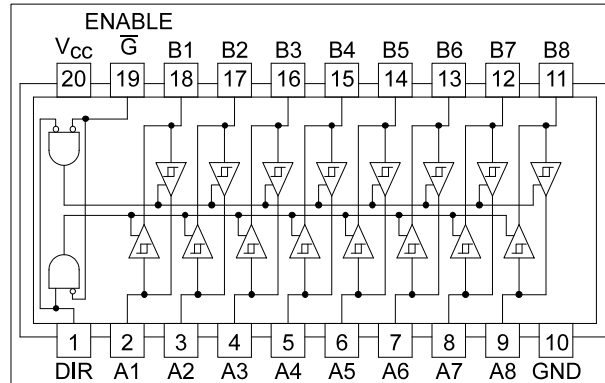

Figure 8-1. Digital IC 74LS245 Block Diagram.

- Circuit 1 - Pins 2 through 9 and 11 through 18 are all the same function. Each pin is connected to both an input and an output of a buffer.
- Circuit 2 - Pins 1 and 19, although they have different names, are both enables and are inputs to AND gates.
- Circuit 3 - Power supply ground input, pin 10.
- Circuit 4 - Power supply V_{CC} input, pin 20.

Each circuit type will produce a different analog signature. Because there are only four types of circuits on the chip, there will be only four unique analog signatures when out of circuit.

Signatures of a Digital IC

Do the following to display the analog signatures of a digital IC (out of circuit):

1. Select the 20V, 10K Ω , 200Hz Range.
2. Place or clip the black test lead from the Access DH2 Tracker's Common jack to the IC's ground pin. For this example, the ground pin of the 74LS245 is pin 10.
3. Use the red test lead from the Access DH2 Tracker's Channel A jack. Probe each pin of the IC and view its signature on Access DH2 Tracker's signature display. For this example, pins 2 to 9 and 11 to 18 are all buffer circuits so they will have identical signatures. (Note: This is only for ICs out of circuit.)
4. Use the red test lead from the Access DH2 Tracker's Signal jack. Probe the enable input pins of the IC and view their signatures on the signature display. For this

example, the enable pins of the 74LS245 are pin 1 and 19 and will have the same signatures. (Note: This is only for ICs out of circuit.)

5. Change the range to 10V, 100Ω, 200Hz. Use the red test lead from the Access DH2 Tracker's Signal jack. Probe the power supply V_{CC} input pin and view its signature on the signature display. For this example, the V_{CC} pin of the 74LS245 is pin 20.

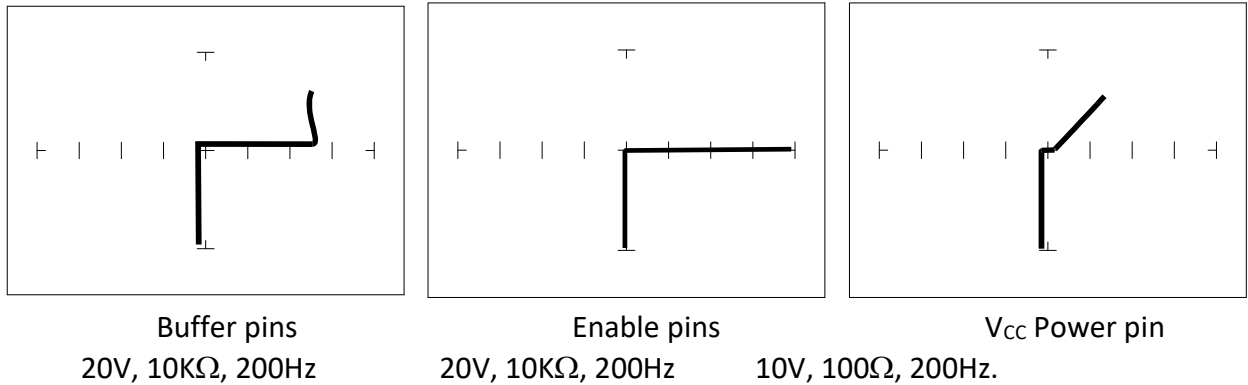

Figure 8-2. Signatures of a Digital IC, 74LS245. Ground Pin to Test Common

Compare these signatures with other signatures of discrete components such as transistors and diodes. Note that there are quite a few similarities here.

Signatures of Logic IC Families

There are a wide variety of logic circuit families. Each has its special functions, advantages and limitations. They range from TTL and its variations (F, LS, S, etc.), emitter-coupled logic (ECL), to the complementary metal oxide semiconductor (CMOS) and its variations (C, HC, HCT, VC, etc.).

Comparing Two TTL Families

Although the logic function is the same, there are differences in the circuitry of each logic family. These differences can be readily seen in their signatures using the Access DH2 Tracker.

We will illustrate these concepts with the following example of two hex inverters, a 7404 and a 74LS04 from different logic families. From the logic diagram below, you can see that they have the same logic functions and pin order. The difference is that the LS chip uses Schottky transistors in its internal construction for increased performance and reduced power consumption. Note that there are only four types of circuit connections and therefore only four signatures on this chip: inverter inputs, inverter outputs, V_{CC} and ground.

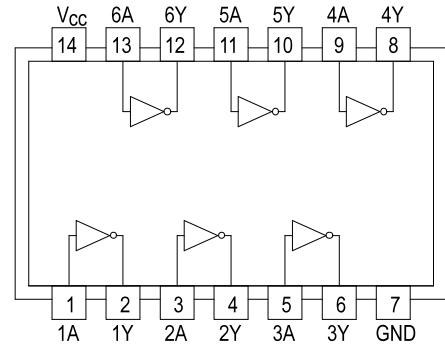

Figure 8-3. Diagram of 7404 & 74LS04.

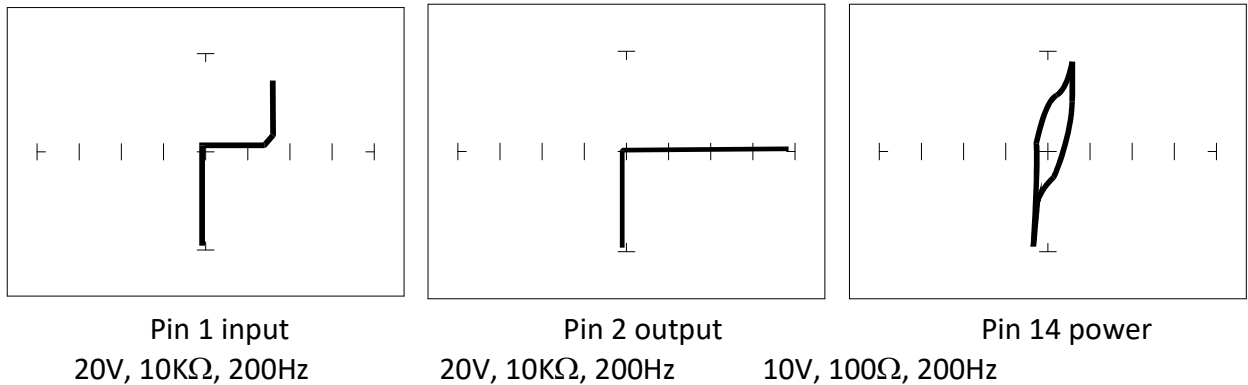

Figure 8-4. Signatures of a 7404 Hex Inverter.

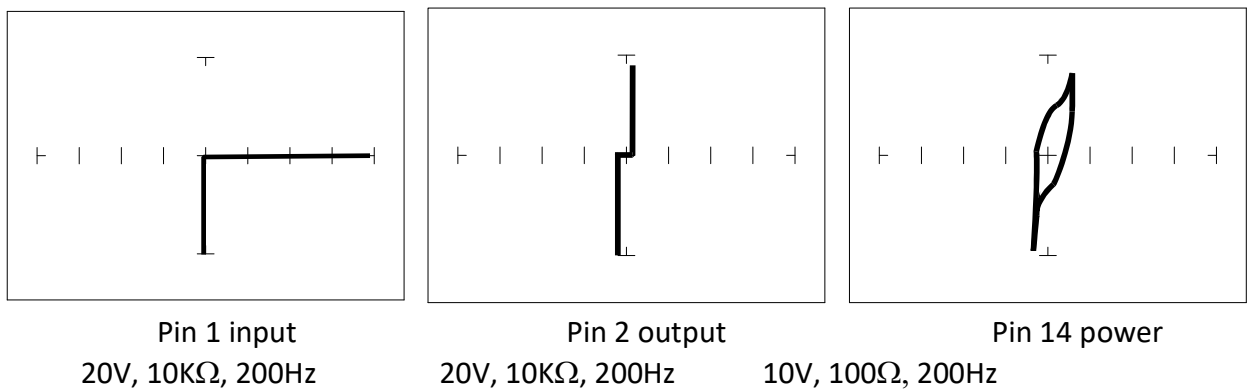

Figure 8-5. Signatures of A 74LS04 Hex Inverter.

Note the differences between the two logic families. They have the same logic function but different construction, therefore different signatures. To test one of these chips

without another reference chip available just compare each input's signature with the other five inputs. Similarly, compare each output's signature with the other five outputs.

CMOS Logic Family

CMOS circuits are constructed differently than TTL circuits. The inputs to CMOS transistors are capacitive due to the use of field-effect transistors (FET) instead of bipolar transistors used in TTL.

In this example, we will choose a 74HC14 Schmidt Trigger Hex Inverter. The HC designation means that it's a member of the high-speed CMOS logic family. From the block diagram of this part, you can see that it has only four different circuit functions. They are inverter input, inverter output, power supply V_{CC} input and power supply ground.

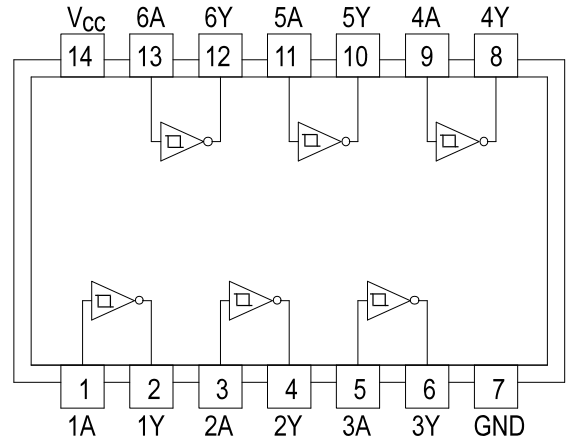
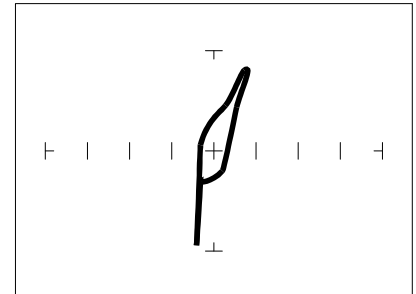
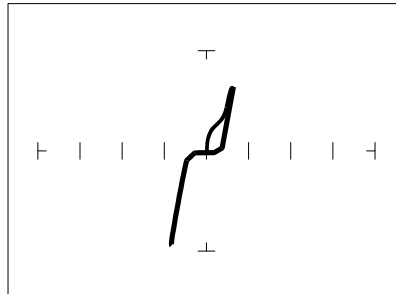
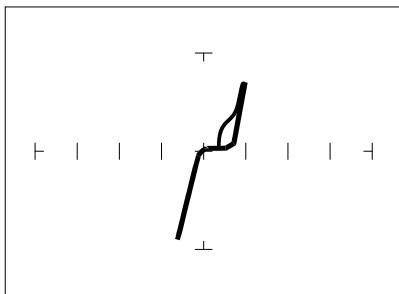

Figure 8-6. 74HC14 Block Diagram.

Do the following to display the analog signatures of a digital IC:

1. Select the 50 Ω and 10V, 60 Hz range.
2. Place or clip the black test lead from the Access DH2 Tracker's Common jack to the IC's ground pin. For this example, the ground pin of the 74HC14 is pin 7.
3. Use the red test lead from the Access DH2 Tracker's Signal jack and probe each pin of the IC. For this example, pins 1, 3, 5, 9, 11 and 13 are all input buffer circuits so they will have identical signatures. (Note: This is only for ICs out of circuit.)
4. Similarly, use the red test lead and probe the output buffer pins 2, 4, 6, 8, 10 and 12. These pins will have the same signatures. (Note: This is only for ICs out of circuit.)
5. Use the red test lead from the Access DH2 Tracker's Signal jack and probe the power supply V_{CC} input pin. For this example, the V_{CC} pin of the 74HC14 is pin 14.



Pin 1 - Input

Pin 2- Output

Pin 14 - V_{CC}

50Ω, 10V, 60Hz Range

Figure 8-7. Signatures of A 74HC14 CMOS Hex Inverter.

CMOS Components and Test Frequency (F_s)

CMOS logic circuits inherently have a significant amount of internal capacitance. This junction capacitance is visible in the CMOS signatures when using the Access DH2 Tracker. Capacitance in CMOS circuitry may be emphasized or de-emphasized by changing the frequency of the test signal.

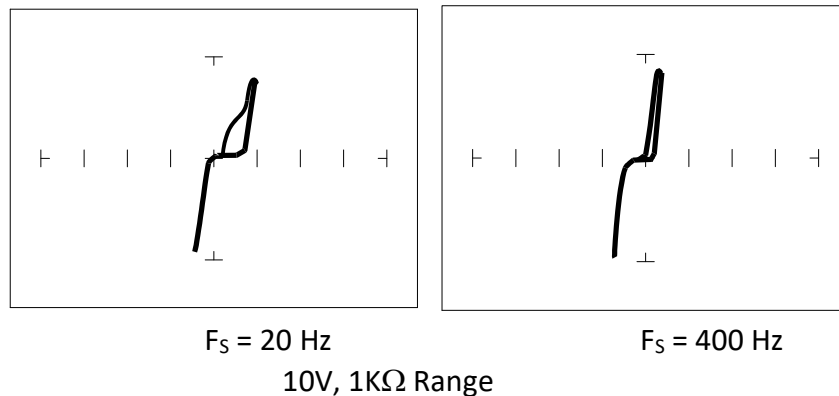

Figure 8-8. Signatures of A 74HC14 Input Pin At Different Frequencies.

Troubleshooting Digital Logic ICs

Comparison testing is a very powerful and effective test strategy when troubleshooting digital logic using ASA. The Access DH2 Tracker's Alt feature makes this technique quick and simple. Instead of having to remember the specific signatures of a good component, all that's needed is to have a reference component or board along-side the one that's suspect. This section gave many examples of signatures from TTL, Schottky TTL and CMOS logic families. Although from first inspection, these signatures appear to be complex, remember that each of the ICs in the examples had really only four unique signatures (buffer input, buffer output, power supply VCC and power supply ground). We can use this characteristic to develop an effective model for troubleshooting digital logic chips.

1. Select the 50Ω, 10V and 60 HZ range
2. Place or connect the black or blue ground clip lead from the Access DH2 Tracker's Common jack to both reference and suspect ICs or the board's ground pin.
3. Place or clip the red test lead from the Access DH2 Tracker's Channel a test terminal to the reference or known good IC's pin. For this example, start with pin 1 of the known good IC.
4. Observe the signature. This is the signature of the pin of the known good component.

5. Keep the red probe on pin 1, an input pin. Probe all the other input pins of the suspect component with the black probe until you have identified all the pins that have signatures that are the same as pin 1.
6. Move the red probe on pin 2, an output pin. Probe all the other output pins of the suspect component with the black probe until you have identified all the pins that have signatures that are the same as pin 2.

Review

- Integrated circuits are complex devices that are built using basic electronic components.
- The IC signatures resemble Zener diodes.
- There are many causes for IC failures and the Access DH2 Tracker can display its "health" as resistive leakage, an open or a short.
- Functionally identical pins on a single IC out-of-circuit will display the same signature.
- The most common point for reference is ground, but V_{CC} or another point might give a more informative signature.
- Different logic families exhibit different characteristic signatures.

Applications

- Testing for faulty IC's is one of the more common uses for the Tracker. A technician can compare IC's in or out of circuit.

8-2 Analog Circuits

Analog components and circuits represent another family of integrated circuits and include operational amplifiers (Op Amps), comparators, references, regulators, timers and many other specialized functions. These components and circuits present more troubleshooting challenges that are unique to this particular family of ICs...

Op Amps

Frequently, each pin of an op amp creates a different signature on the Access DH2 Tracker. This signature is the result of the internal design of the chip and both the internal and external circuit elements connected to it. This type of analog component typically has many internal junctions connected to each pin and each pin may also be connected to numerous external components.

The following example will demonstrate ASA with a commonly used 741 type Op Amp. In this case it is configured as an inverting amplifier circuit as in the schematic below.

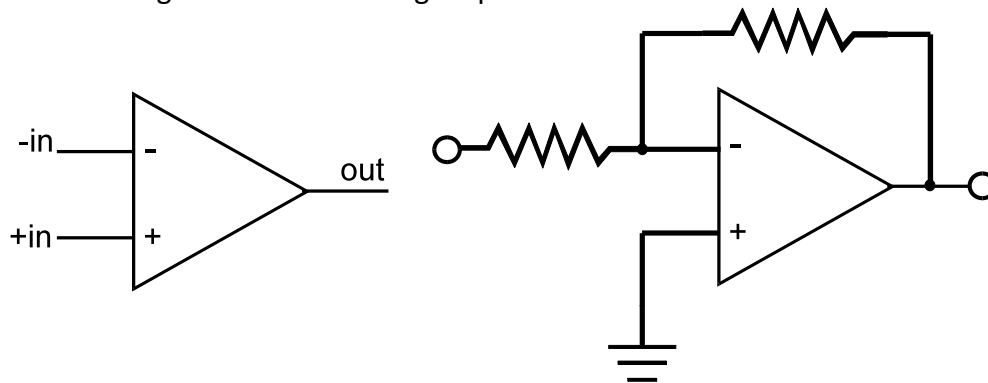

Figure 8-9. Op Amp Symbol and Schematic Diagram of an Inverter Circuit.

We will examine the signatures of this analog IC and present some troubleshooting concepts for this type of component.

Op Amp Signatures

Do the following to display the analog signatures of an op amp:

1. Select the 1K Ω , 15V, 60Hz.
2. Place or clip the black test lead from the Access DH2 Tracker's Common jack to the IC's ground or a power supply pin. For this example, the negative power supply pin of the 741 is pin 4 and the positive power supply is pin 8.
3. Use the red test lead from the Access DH2 Tracker's Signal jack and probe each pin of the IC.
4. Observe that the signatures of each of the op amp's pins are unique.

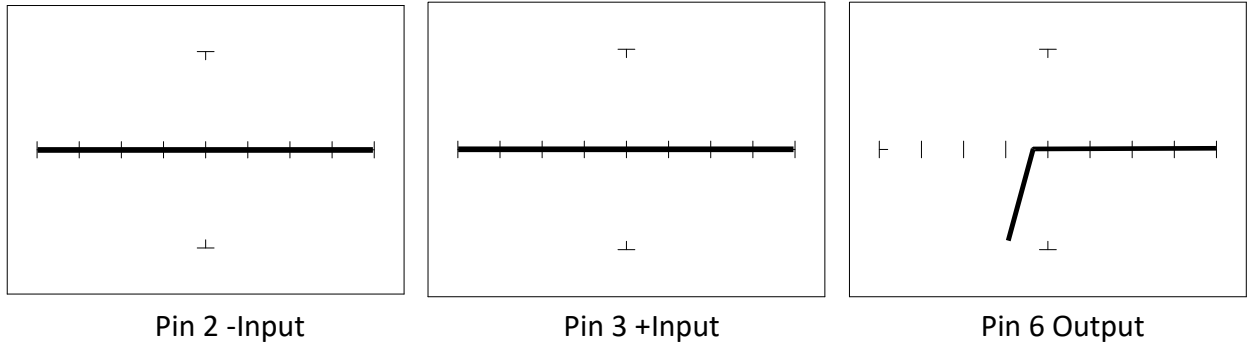

Figure 8-10. Signatures of an Op Amp (741) at 10V, 50Ω, 60Hz with Common to Pin 4.

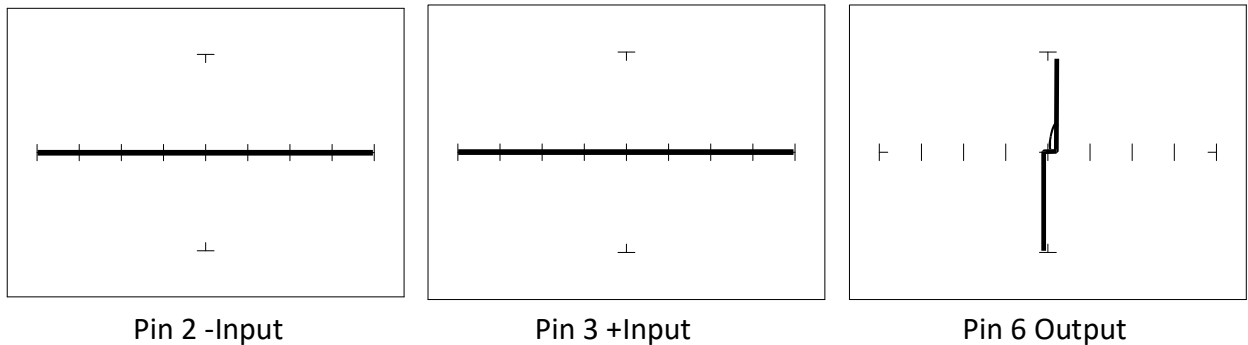

Figure 8-11. Signatures of an Op Amp (741) at 20V, 20KΩ, 60Hz with Common to Pin 4.

Troubleshooting Op Am Circuits

Troubleshooting an op amp in-circuit may be very challenging. These circuits usually have numerous connections that act as feedback or compensation loops. This results in almost an infinite number of possible analog signatures. Use the comparison test method when troubleshooting op amps in-circuit. In this case, components on a suspect board are compared to those on a known good board. The Access DH2 Tracker can help locate the defective component quickly.

The op amp has three main terminals; + input, - input and output. An alternative way to perform ASA on the op amp is to connect Access DH2 Tracker's Common terminal to the op amp's output while making a comparison with the red test probe to the "+" and then the "-" leg. This eliminates problems encountered when probing op-amps that are isolated from power and common. When there is more than one op amp in a package, compare one with the other. The dual op amp and quad op amps are very common. This technique also works with comparators.

Linear Voltage Regulators

Voltage regulators are commonly found in many electronic assemblies. Some of the most popular integrated circuits of this type are three terminal devices like the 7805, a +5V DC regulator. The next figure shows the schematic and pin layout of the 7805. Different manufacturers implement their products with different topologies and manufacturing processes. It is not unexpected that the same functionally equivalent component from different manufacturers may have different signatures.

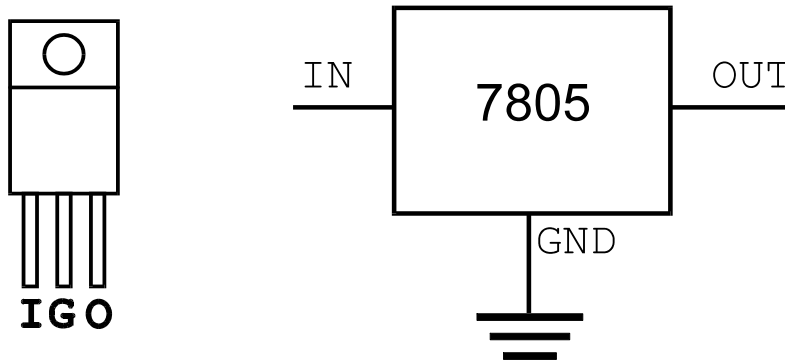

Figure 8-12. Diagram and Symbol of a Linear Voltage Regulator, 7805 Type.

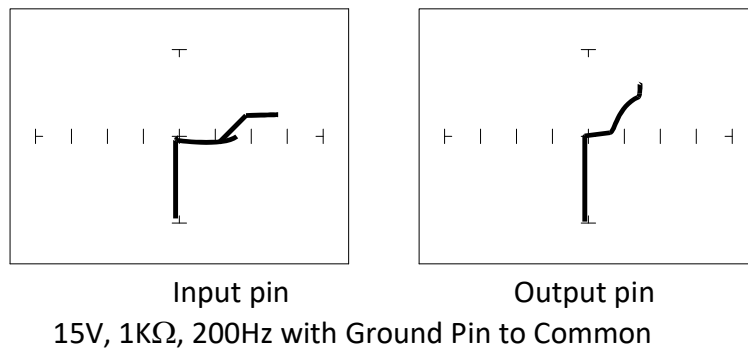

Figure 8-13. Signatures of A 7805 SGS Thompson Voltage Regulator

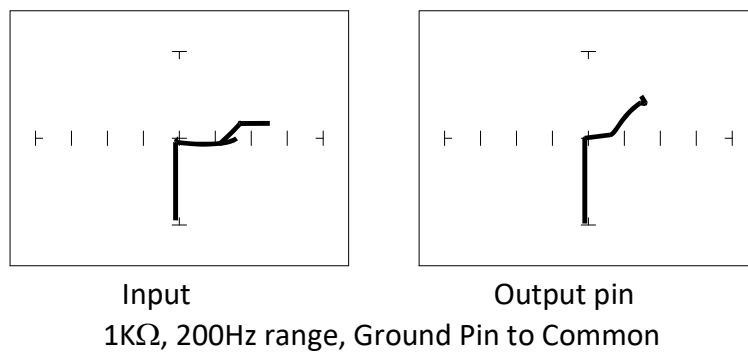

Figure 8-14. Signatures of a 7805 Motorola Voltage Regulator.

Review

- Integrated circuits are complex devices that are built using basic electronic components.
- The IC signatures resemble Zener diodes.
- There are many causes for IC failures and the Access DH2 Tracker can display its "health" as resistive leakage, an open or a short.
- Functionally identical pins on a single IC out-of-circuit will display the same signature.
- The most common point for reference is ground, but V_{CC} or another point might give a more informative signature.
- Different analog IC families exhibit different characteristic signatures.

Applications

- Testing for faulty IC's is one of the more common uses for the Tracker. A technician can compare IC's in or out of circuit.

8-3 Low Voltage Integrated Circuits

There is a new family of logic that offers lower dynamic power consumption, lower operating voltages, higher output drive, faster AC speed, lower noise and better dynamic thresholds than HC CMOS. These features make this family attractive for low power applications such as battery operated portable applications (that is, laptop computers, pagers, phones, etc.).

In order to achieve this new improved level of performance, the manufacturers of this LV (low voltage) family of logic ICs have redesigned the internal structure of the device. Some manufacturers have changed the input structure by eliminating the input protection diode to V_{CC} . The design of the output structure also has changed by eliminating the output protection diode to V_{CC} and replacing it with an N-Channel pull-up transistor. As a result of these changes, the analog signatures of the LV logic family are different from the conventional HC logic family.

Do the following to view signatures of low voltage logic:

1. Select the 3V, 10K Ω and 60Hz.
2. Connect the black test lead from the Access DH2 Tracker's Common jack to the IC's ground pin. For this example, the ground pin of the 74LVQ245 is pin 10.
3. Use the red test lead from the Access DH2 Tracker's Channel A jack and probe each pin of the IC. For this example, pins 2 to 9 and 11 to 18 are all buffer circuits so they will have identical signatures. (Note: This is only for ICs out of circuit.)
4. Use the red test lead from the Signal jack and probe the enable input pins. For this example, the enable pins of the 74LVQ245 are pin 1 and 19 and will have the same signatures. (Note: This is only for ICs out of circuit.)
5. Use the red test lead from the Access DH2 Tracker's Signal jack and probe the power supply V_{CC} input pin 20.

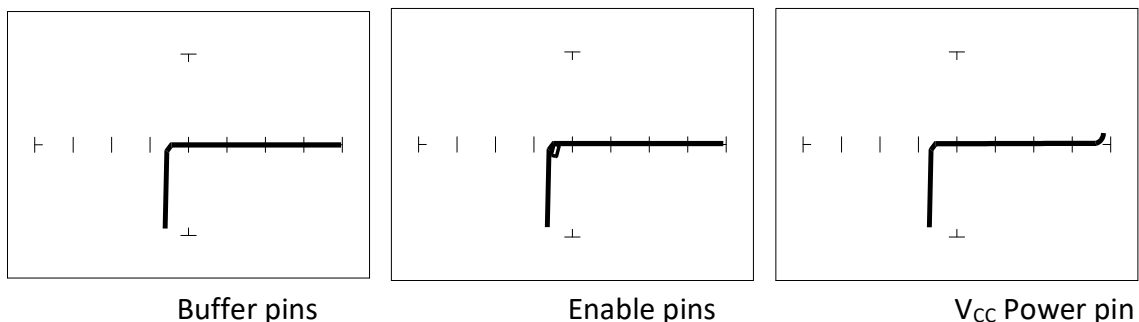

3V, 10K Ω , 60Hz, Ground Pin To Test Common

Figure 8-15. Signatures of a Low Voltage IC (74LVQ45 Type).

The ranges used above enhance the resistive fault signatures that are commonly found when troubleshooting this logic family. The test signal voltage V_S is lower than the TTL range groups to ensure that most descriptive signature is displayed. A higher V_S may result in a signature going toward a short which would mask out flaws. The short signature can be attributed by the LV family's lower voltage characteristics.

Compare these signatures with the CMOS logic family and other discrete components such as transistors and diodes. Note that these signatures have some common similarities with the other components' analog signature we have seen already.

Review

- Integrated circuits are complex devices that are built using basic electronic components.
- The IC signatures resemble regular and Zener diode signatures.
- There are many causes for IC failures and the Access DH2 Tracker can display its "health" as resistive leakage, an open or a short.
- Functionally identical pins on a single IC out-of-circuit will display the same signature.
- The most common point for reference is ground, but V_{CC} or another point might give a more informative signature.

Applications

- Testing for faulty IC's is one of the more common uses for the Tracker. A technician can compare IC's in or out of circuit.

SECTION 9 APPLICATION NOTES

9-1 *How to Use Commons*

The Huntron Access DH2 commons are marked COM, COM1, COM2, COM3 and COM4. These common terminals are used for applications requiring more than one Common connection to the printed circuit assembly. For example, you may want to setup a board so that some components are tested with respect to the Ground terminal and others with respect to VCC or any other power supply rail. Even though no power source is applied to the printed circuit assembly, signatures may appear significantly different with respect to different Common references.

NOTE: Even though 4 Commons are available for physical connection to the printed circuit assembly, only a combination of any 2 of those 4 Commons will get shorted to the main COM terminal.

For example, In the Huntron Workstation software each range can be tested relative to Common 1 or Common 2 or Common 3 or Common 4. You will have to set up 4 ranges, each with a different **Prober Common** if you want to test it relative to all the above Commons.

9-2 Access DH2 Connection Diagram

The connections on the front panel of the electronics chassis inside the front doors and the internal Access DH2 Tracker can be switched using software controls. These diagrams may be useful to help you understand the connection capabilities of the Access DH2. The second diagram is for earlier versions of the Access DH2 that had BNC oscilloscope connectors.

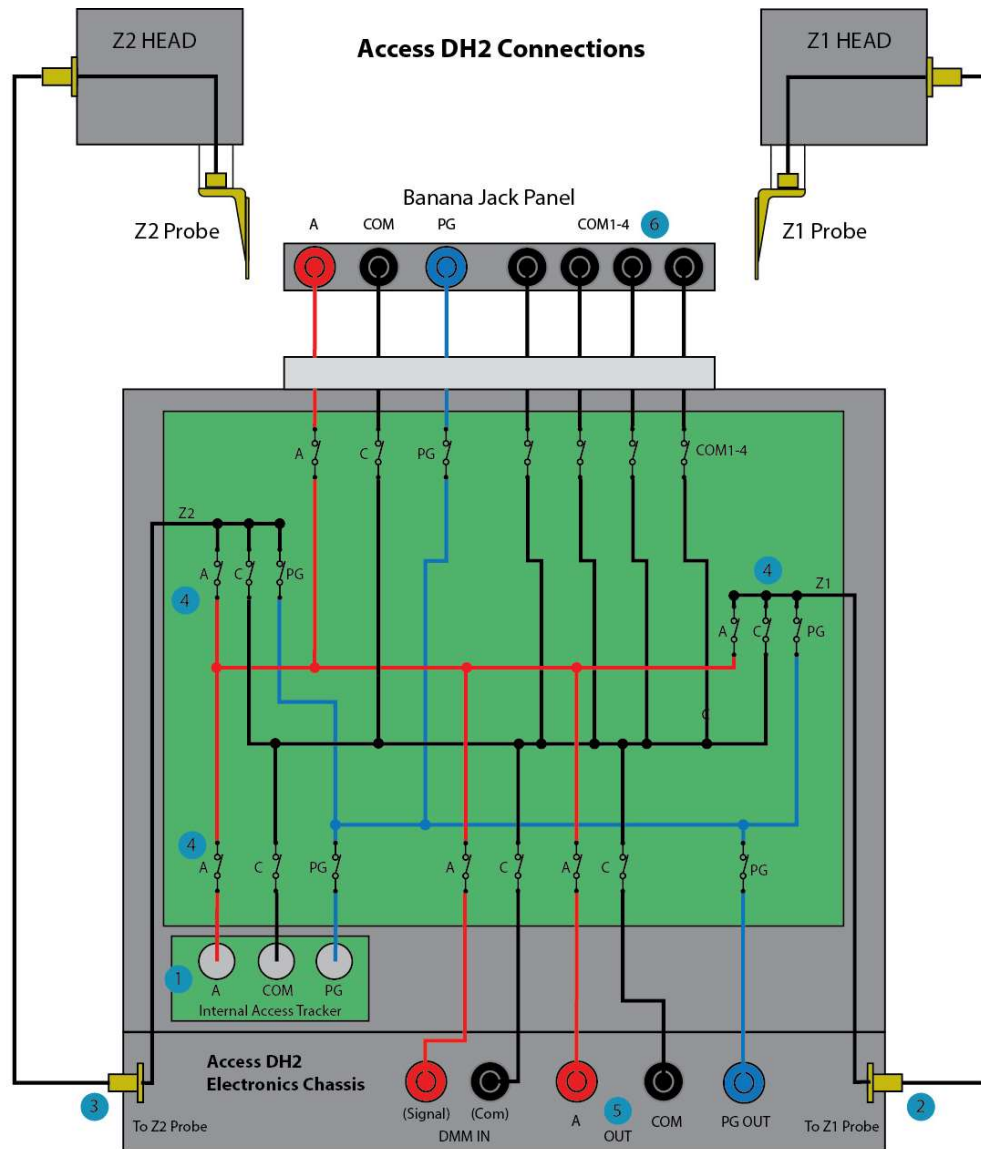

Prober Signal and Common Line Controls

- 1 Internal Tracker (Access Tracker)
- 2 Signal Line (A) Control (Pin level) - Z1 Signal checked Z2 is Common
- 3 Signal Line (A) Control (Pin level) - Z1 Signal unchecked Z1 is Common
- 4 Channel A, C (Common) or Pulse Gen (PG) selection (Pin level)
- 5 OUT (External Instrument) (Tools/Options/Hardware settings for instrument)
- 6 Prober Common 1-4 selection (Range level)

Relay description

Internal Tracker: A = K25; C = K26; PG = K27
 Z1: A = K18; C = K20; PG = K17
 Z2: A = K19; C = K21; PG = K22
 Prober Common: 1 = K11; 2 = K12; 3 = K13; 4 = K14
 OUT: Signal = K7; C = K6
 DMM: Signal = K4; C = K5

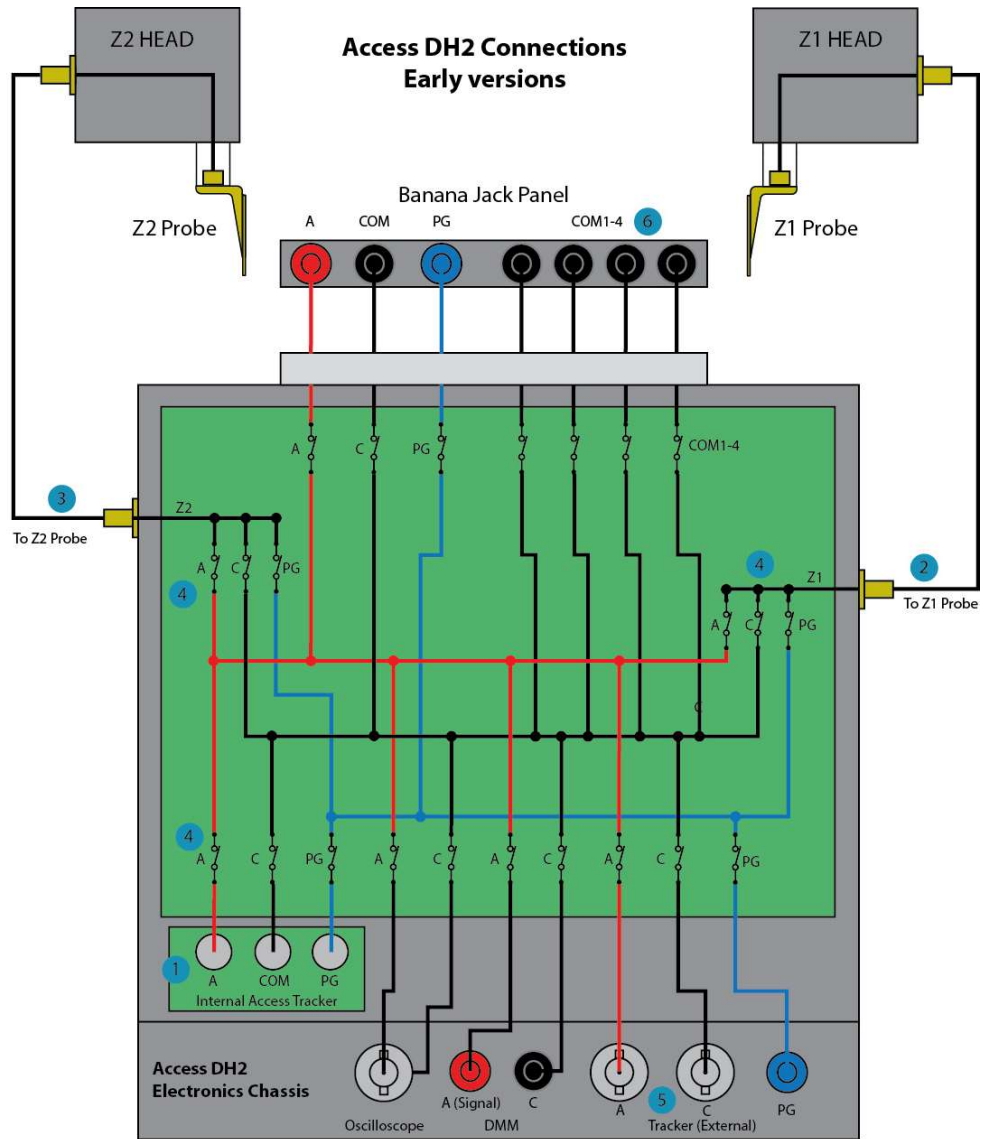

Prober Signal and Common Line Controls

- 1 Internal Tracker (Access Tracker)
- 2 Signal Line (A) Control (Pin level) - Z1 Signal checked Z2 is Common
- 3 Signal Line (A) Control (Pin level) - Z1 Signal unchecked Z1 is Common
- 4 Channel A, C (Common) or Pulse Gen (PG) selection (Pin level)
- 5 External Tracker (Tools/Options/Hardware settings for instrument)
- 6 Prober Common 1-4 selection (Range level)

Relay description

Internal Tracker: A = K1; C = K2; PG = K3
 Z1: A = K18; C = K20; PG = K17
 Z2: A = 19; C = K21; PG = K22
 Tracker (External): A = K1; C = K2; PG = K3
 Prober Common: 1 = K11; 2 = K12; 3 = K13; 4 = K14
 OSC: Signal = K7; C = K6
 DMM: Signal = K4; C = K5

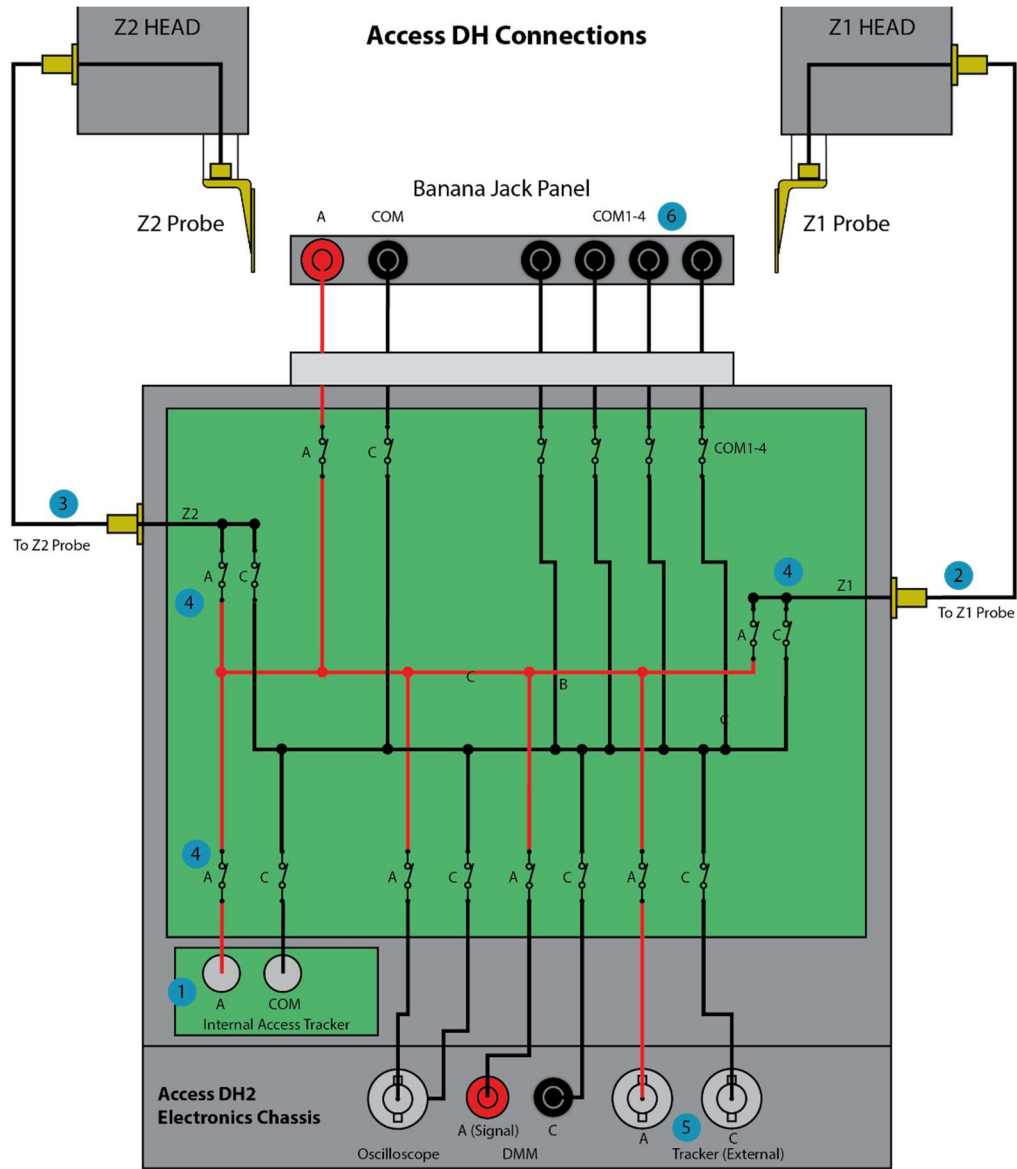

Prober Signal and Common Line Controls

- 1 Internal Tracker (Access Tracker)
- 2 Signal Line (A) Control (Pin level) - Z1 Signal checked Z2 is Common
- 3 Signal Line (A) Control (Pin level) - Z1 Signal unchecked Z1 is Common
- 4 Channel A, C (Common) selection (Pin level)
- 5 External Tracker (Tools/Options/Hardware settings for instrument)
- 6 Prober Common 1-4 selection (Range level)

Relay description

Internal Tracker: A = K1; C = K2
 Z1: A = K18; C = K20
 Z2: A = 19; C = K21
 Tracker (External): A = K1; C = K2
 Prober Common: 1 = K11; 2 = K12; 3 = K13; 4 = K14
 OSC: Signal = K7; C = K6
 DMM: Signal = K4; C = K5